

OJIYAS

Brand of High Accuracy

CATALOG



OJIYA SEIKI CO., LTD.



AIR MICROMETER

AIR GAUGE

GAUGE

CATALOG
No.15



OJIYAS

Brand of High Accuracy

オチャセイキをあらわす「OJIYA」にセイキの頭文字「S」をジョイント。
また「S」は複数形も意味しており、オチャセイキのブランドとして表現している。
製品にこのマークを刻印することにより、高い品質を保証するものである。

OJIYAS, that is the trademark of OJIYA SEIKI, comes from the word of OJIYA and the first letter of SEIKI which stand for 'accurate machinery'.

The letter S can also be read as the plural form of OJIYA, where OJIYA is understood to be OJIYA SEIKI products. Thus, "OJIYAS" indicates the various products made by this company.

"OJIYAS" is used as the brand name to guarantee the high quality of the products.

Index

空気マイクロメータ	1
Air Micrometer	
ad-L8	コラム型デジタル式空気マイクロメータ 2
	Column Model Digital Type Air Micrometer
AIR GIRL-F	流量式空気マイクロメータ 4
	Flow Type Air Micrometer
空気マイクロメータ用測定子	5
Air Jet Gauge for Air Micrometer	
IA型 内径測定子	Air Jet IA Type for Inside Diameter
IB型 内径測定子	Air Jet IB Type for Inside Diameter
IC型 内径測定子	Air Jet IC Type for Inside Diameter
LA・LB型 内径測定子	Air Jet LA・LB Type for Inside Diameter
VC・LV型 外径測定子	Air Jet VC・LV Type for Outside Diameter
OR・LR型 外径測定子	Air Jet OR・LR Type for Outside Diameter
空気マイクロメータ用マスターゲージ	11
Master Gauges for Air Micrometer	
平行ねじ用限界ゲージ	14
Limit Gauges for Parallel Threads	
標準ねじゲージ	14
Standard Thread Gauges	
管用平行限界ねじゲージ	15
Limit Gauges for Parallel Pipe Threads	
G規格	G
PF規格	PF
管用テーパねじゲージ	16
Gauges for Taper Pipe Threads	
R規格	R
PT規格	PT
NPT規格	NPT
NPTF規格	NPTF
限界プレーンゲージ	20
Plain Limit Gauges	
限界プラグゲージ (栓ゲージ)	Limit Plug Gauges
超硬ゲージ	Carbide Gauges
限界リングゲージ	Limit Ring Gauges
ハサミゲージ	Snap Gauges
マスターゲージ	23
Master Gauges	
スプラインゲージ	23
Spline Gauges	
テーパゲージ	23
Taper Gauges	
特殊ゲージ	24
Special Gauges	
目盛付ねじ深さゲージ	25
Thread Depth Gauge with Graduation Scale	
ゲージ在庫表	27
Stock List of Gauges	
技術資料	30
Technical Information	
校正点検	37
Periodic Inspection	
注意事項	38
Cautions	
会社概要	40
Introduction to OJIYA SEIKI	

AIR MICROMETER

OJIYAS

空気マイクロメータ

空気マイクロメータは微小な寸法変位量を高圧の空気の量や背圧(差圧)を利用し流体力学の原理を応用した精密比較測定器です。無接触で迅速に測定ができ、さらに被測定物の実測寸法を読み取ることができます。測定点数に応じ容易に多連式に積み上げることができることも大きな特長です。品質管理、測定能率の向上に最適な測定器です。

Air micrometer is a precision comparator type measuring instrument that employs air flow volumes and air pressure to determine the size of measured part dimensions. Operation is noncontact and is as simple as presenting a tool to a workpiece and observing a reading. A row of multiple column can be used for measuring several measuring points in one glance that can reduce measurement times. The benefit of air gauging is its ease of use, which produces accurate results even when used by unskilled operators. Therefore, air micrometer is an effective and efficient shopfloor measuring tool used in quality control.

AIR GIRL Flow Type



ad-L8 Digital Type



ad-L8 Digital Type

コラム型デジタル式空気マイクロメータ

COLUMN MODEL DIGITAL TYPE

AIR MICROMETER



使いやすさと見やすさを追求したコラム型デジタル式空気マイクロメータです。

アナログ3色カラーバー（緑色、赤色、橙色）表示とTFTカラー液晶ディスプレイの採用でセッティング、マスタリング時の操作入力はもちろん測定寸法の把握も素早く対応できます。

空気回路は差圧センサーを採用したことにより元圧側の圧力変動に測定値が影響されない仕様となっています。

A column model air micrometer with a great emphasis upon ease of use and viewing.

By using 3 colors (red, green and orange) LED bar and TFT LCD screen, operation for parameter setting and identification of measured results can be easily and quickly accomplished.

Differential pressure type circuit is adopted to compensate the variations in the pressure of the air source that could spoil the measurement.

操作は液晶画面に表示されるメニューから選択と入力!!

The operations are performed from the visible menu displayed on the LCD screen

測定システムはエアマイクロメータ本体（フィルタユニット、接続用ウレタンホース：標準付属品）と測定ジェットおよびマスターゲージで構成されています。

なお測定ジェットには接続用ビニールホースが附属されています。

The AIR MICROMETER measurement unit consists of the main body of AIR MICROMETER (including the filter unit, hose for connection as standard accessories), air jet and master gauges. Vinylhose is attached in the air jet for connection.

メニュー概要

Menu Configuration

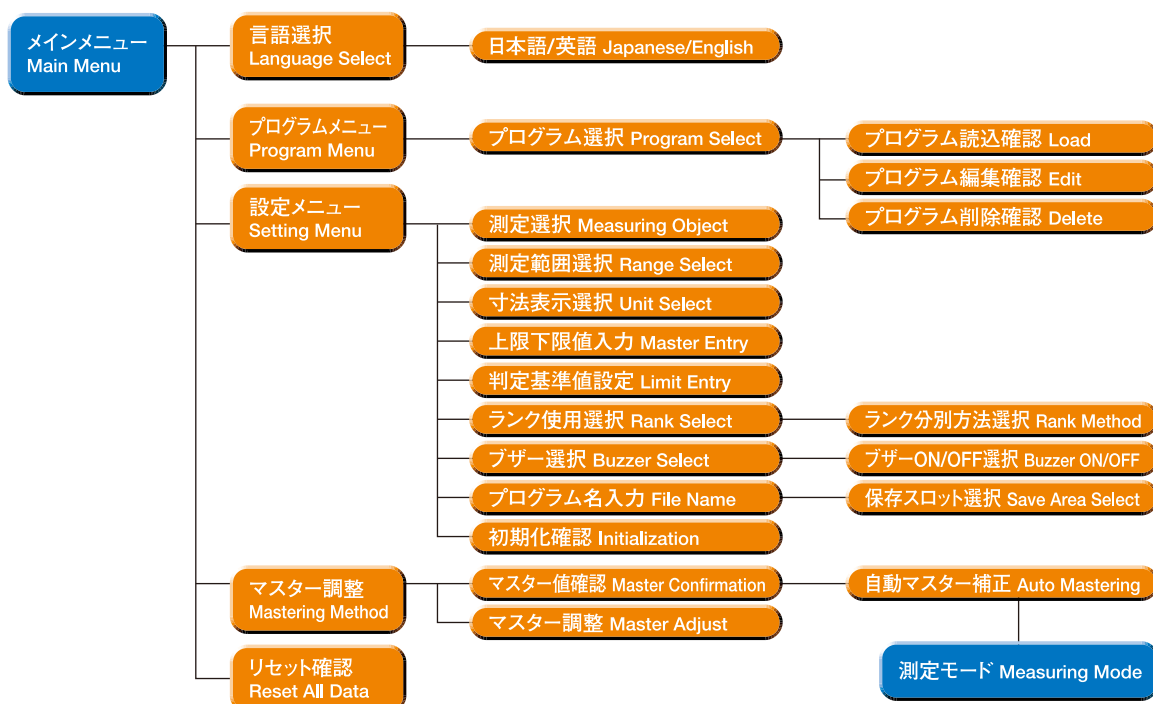

特 長

Features

- 1 日本語、英語表示切換え機能搭載
- 2 操作性抜群のパネルスイッチ
17の独立キースイッチでスピーディーな入力が可能
- 3 自動マスター補正機能
大範、小範を使用して自動でセッティングします
- 4 ワーク寸法ランク選別機能
OK領域で任意設定、最大100ランク
- 5 最大、最小測定寸法を表示
最大、最小の差で真円度、テーパ度の判定ができます
- 6 測定、判定結果を数値と音でお知らせ
データ表示の他ブザー音を任意で設定できます
- 7 シリアル出力にUSBポート,RS485装備
パソコン,RS485対応インターフェースへのデータ出力を行います



- 1 Japanese/English language selection function
- 2 Excellent operability provided by panel switch having 17 button keys
- 3 Auto master compensation function
Auto mastering using maximum and minimum masters
- 4 Rank function for sorting the measured values into a group of values
Rank is available up to 100 ranks within the OK zone
- 5 The maximum and minimum peak detection is available
The peak detection can be used to measure the roundness, taper degree
- 6 Buzzer and digital display are used for exhibiting the measured results and their OK/NG status
Buzzer can be set optionally from extended menu
- 7 USB connector, RS485 for serial interface
To send the measured results to the computer and RS485 compatible interface

仕 様

Specifications

本体寸法 Dimension	巾 Width 50mm	奥行 Depth 197mm	高さ Height 527mm	重量 Weight 4kg
電源供給 Power Supply	AC100V~AC240V			
電源容量 Power Capacity	30VA			
電圧変動率 Voltage Regulation	20%以下 within 20%			
周波数 Frequency	50Hz / 60Hz			
供給空気圧 Air Pressure	350~700kPa			
使用温度 Operating Temperature	0~40°C			

測定レンジ Measurement Range	20μm	50μm	100μm	200μm
表示分解能 Display Resolution	0.2μm	0.5μm	1μm	2μm
バー表示 LED Bar Graph	101ドット 101dot			
デジタル表示 Digital Display	カラー液晶(LCD)表示 TFT Color LCD			
自動マスター補正範囲 Auto Mastering Range	大範合せ値 Master Max -20%		小範合せ値 Master Min +20%	
シリアル出力 Serial Output	USBポート USB port, RS485			
ランク機能 Rank Function	最大100ランク (OK領域) Max 100 rank			

性 能

Performances

項目 Items	測定レンジ Range	判定基準 (許容値) Standard Performances			
		20μm	50μm	100μm	200μm
基準内器差 Instrumental error		0.4μm	1μm	2μm	4μm*
繰返し精度 Repeatability		0.2μm	0.5μm	1μm	2μm
指示の安定性 Stability of Indication		0.2μm	0.5μm	1μm	2μm
応答時間 Response Time		1.2秒以内 Max 1.2 Sec			
有効指示範囲 Effective Indication Range		20μm	50μm	100μm	160μm

*測定範囲が200μmの場合、有効指示範囲の160μmにおいて判定基準値が4μmですが、フルレンジにおいては6μmです。

*For measurement range of 200μm, the instrumental error of 4μm is for effective indication range of 160μm. For full range of 200μm, the standard of instrumental error is 6μm.

AIR GIRL Flow Type

流量式空気マイクロメータ

FLOW TYPE AIR MICROMETER



特長

Features

- 1.美しい流線型スタイル（コンパクト設計のスリムボディ）
- 2.見やすい数字・目盛（視認性の良い黄色地に黒文字）
- 3.やさしい測定操作（必要最小限の簡単な操作）
- 4.非接触測定ですからワークを傷つけません。
- 5.フロートの応答速度が速く安定性に優れています。
- 6.容易に多連式に構成することができます。
- 7.テーパガラス管部に保護カバーを採用しています。

- 1.Compact design with slim body
- 2.Easy reading scale
- 3.Easy operation with minimum function
- 4.Because of noncontact measurement, the workpieces are damage-free
- 5.Quick float speed with superior stability
- 6.Easy to change to multiple columns
- 7.Employed a protection cover to protect the taper tube

測定システムはAIR GIRL本体（フィルタユニット、接続用ウレタンホース：標準付属品）と測定ジェットおよびマスターゲージで構成されています。なお、測定ジェットには接続用ビニールホースが付属されています。

The air girl measurement unit consists of the main body of air girl (including the filter unit, hose for connection as standard accessories), air jet and master gauges. Vinyl hose is attached in the air jet for connection.

仕様

Specifications

項目 Item		巾 Width mm	奥行 Depth mm	高さ Height mm	重量 Weight kg
連数 Columns No.					
単式	Single type	105	186	540	4.9
2連式	Double type	140	186	540	9.9
3連式	Three type	190	186	540	14.3
4連式	Four type		2連式×2台	Double type×2	
5連式	Five type		2連式+3連式	Double type+Three type	
6連式	Six type		3連式×2台	Three type×2	

性能

Performances

項目 Item	型式 Model			
	F10000	F5000	F2000	F1000
基準倍率 (倍) Standard magnification (times)	10,000	5,000	2,000	1,000
指示範囲 (μm) Indication range	20	40	100	200
有効指示範囲 (μm) Effective indication range	15	30	70	150
目量 (μm) Graduation	0.5	1	2	5
指示誤差 (μm) Indication error	0.5以下 Max0.5	1.0以下 Max1.0	1.5以下 Max1.5	3.0以下 Max3.0
指示の繰返し性 (μm) Indication variance	0.3以下 Max0.3	0.5以下 Max0.5	1.0以下 Max1.0	2.0以下 Max2.0
応答時間 (秒) Response time (sec)	2.0以下 Max2.0	1.8以下 Max1.8	1.5以下 Max1.5	1.5以下 Max1.5
供給空気圧 (kPa) Air pressure supplied	290~690			

空気マイクロメータ用測定子 (AIR JET) Air Jet Gauge for Air Micrometer

エアマイクロメータ用測定子 (JET) は空気流体力学を応用し正確に寸法を測定できる測定器です。

エアマイクロメータ本体と測定子 (JET) を接続することにより高圧の空気の流量や背圧を目盛上に拡大して指示します。代表的な測定としては内径測定、外径測定、高さ測定等の他直角度、同軸度、真円度測定等行うことができます。

特に量産加工をしているお客様においては測定時間の短縮による効率化と個々の測定技術に左右されない正確な測定が保証されます。

また、測定キズのはいりやすい柔らかい材質の製品の測定には測定時、非接触にて測定できるエアマイクロメータ用測定子を使用することによりキズ、打コンの防止が図られます。

Air jet is a measuring instrument which measures dimension of the workpieces precisely based on the principles of aerodynamics. By connecting the air jet to the air girl, the gap between the workpiece and the air nozzle that correspond directly to the change in airflow and pressure is displayed in enlarged scale. The system can measure inside and outside diameters, thickness, perpendicularly, cilindricity and circularity tolerances.

A precise and simple measurement is guaranteed. The inspection efficiency of the workpieces in mass-production line can be improved. The workpieces are free from damage because of noncontact measurement. Thus, the system can be used for measuring soft and delicate materials.



測定例 Measurement applications

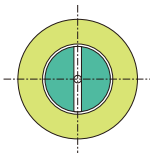

内径・真円度の測定
Inside diameter,
Circularity tolerance

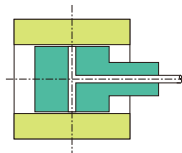

内径・円筒度の測定
Inside diameter,
Cilindricity tolerance

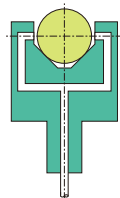

外径・真円度の測定
Outside diameter,
Circularity tolerance

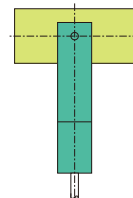

外径・円筒度の測定
Outside diameter,
Cilindricity tolerance

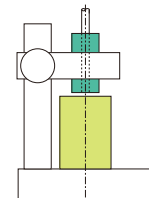

高さ・厚み測定
Height, Thickness

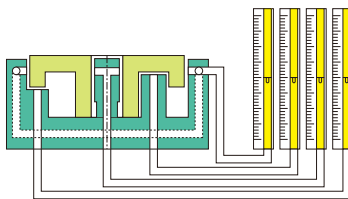

多連測定
Multiple measurement

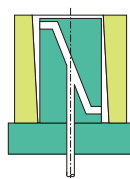

内径と端面の直角度測定
Perpendicularity between
inside diameter and edge part

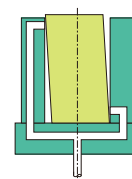

外径と端面の直角度測定
Perpendicularity between
outside diameter and edge part

特殊多連式測定台 Special Type Air Jet Measuring Unit



AIR GAUGE

IA型内径測定子 (直吹タイプ)

Air Jet IA Type for Inside Diameter

ノズル位置がジェット先端より8~20mmにあり、主に通り穴の測定に用いられます。

The nozzle position is 8-20mm from the top point. It is used to measure the through hole.



呼び寸法 ϕd 超え ~ 以下 Nominal Size ϕd exceeded ~ less		L1	L2	L3	L4
4を超え 8以下 4 exceeded 8 or less		8	20	30	90
8を超え 11.5以下 8 exceeded 11.5 or less		8	20	30	90
11.5を超え 14以下 11.5 exceeded 14 or less		15	45	5	85
14を超え 24以下 14 exceeded 24 or less		20	45	5	85
24を超え 40以下 24 exceeded 40 or less		20	45	5	85
40を超え 50以下 40 exceeded 50 or less		20	50	10	100
50を超え 65以下 50 exceeded 65 or less		20	50	10	100
65を超え 100以下 65 exceeded 100 or less		20	50	10	100

$\phi 50$ を超えるサイズは軽減穴が付いた形状となります。

The size that exceeds $\phi 50$ is the shape with lightened hole.

IB型内径測定子（直吹タイプ）

Air Jet IB Type for Inside Diameter

ノズル位置がジェット先端より3~4mmにあり、主に止り穴の測定に用いられます。

The nozzle position is 3-4mm from the top point. It is used to measure the blind hole.



呼び寸法 ϕd 超え ~ 以下 Nominal Size ϕd exceeded ~ less		L1	L2	L3	L4
4を超え 8以下 4 exceeded 8 or less		3	20	30	90
8を超え 11.5以下 8 exceeded 11.5 or less		4	20	30	90
11.5を超え 14以下 11.5 exceeded 14 or less		4	45	5	85
14を超え 24以下 14 exceeded 24 or less		4	45	5	85
24を超え 40以下 24 exceeded 40 or less		4	45	5	85
40を超え 50以下 40 exceeded 50 or less		4	50	10	100
50を超え 65以下 50 exceeded 65 or less		4	50	10	100
65を超え 100以下 65 exceeded 100 or less		4	50	10	100

$\phi 50$ を超えるサイズは軽減穴が付いた形状となります。

The size that exceeds $\phi 50$ is the shape with lightened hole.

AIR GAUGE

IC型内径測定子 (直吹タイプ)

Air Jet IC Type for Inside Diameter (Direct type)

ノズル位置がジェット先端より2mmにあり、主に止り穴の測定に用いられます。

The nozzle position is 2mm from the top point.
It is used to measure hole at the deeper point.

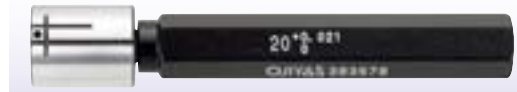

呼び寸法 ϕd 超え ~ 以下 Nominal Size ϕd exceeded ~ less		L1	L2	L3	L4
4を超え 8以下 4 exceeded 8 or less		2	20	30	90
8を超え 11.5以下 8 exceeded 11.5 or less		2	20	30	90
11.5を超え 14以下 11.5 exceeded 14 or less		2	25	5	85
14を超え 24以下 14 exceeded 24 or less		2	25	5	85
24を超え 40以下 24 exceeded 40 or less		2	25	5	85
40を超え 50以下 40 exceeded 50 or less		2	25	10	100
50を超え 65以下 50 exceeded 65 or less		2	25	10	100
65を超え 100以下 65 exceeded 100 or less		2	25	10	100

$\phi 50$ を超えるサイズは軽減穴が付いた形状となります。
The size that exceeds $\phi 50$ is the shape with lightened hole.

LA型・LB型内径測定子（間接タイプ）

Air Jet LA and LB Types for Inside Diameter (Indirect type)

コンタクトリーフ（板バネ）の測定ポイント部に超硬ボールを用い測定する接触式測定子です。主に測定面の幅が4mm以下または、表面粗さが6Sより粗い場合に用いられます。

It is a contact type air jet which uses carbide ball on the measurement point.
It is used to measure the workpieces having surface roughness more than 6S or width of the measured surface less than 4 mm.



LA型 LA Type

超硬ポイントが測定ヘッドの中間よりにあるタイプがLA型となります。

LA type is the type with position of carbide ball in the middle of the jet.

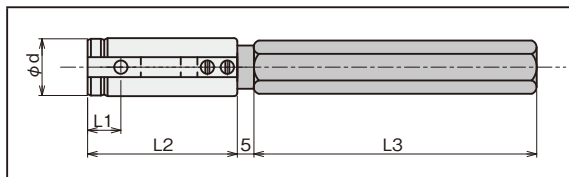

呼び寸法 φd 超え～以下 Nominal Size φd exceeded ~ less	L1	L2	L3
10を超え 14以下 10 exceeded 14 or less	7	45	95
14を超え 20以下 14 exceeded 20 or less	8	45	85
20を超え 24以下 20 exceeded 24 or less	10	45	85
24を超え 40以下 24 exceeded 40 or less	10	45	85
40を超え 50以下 40 exceeded 50 or less	15	50	100
50を超え 65以下 50 exceeded 65 or less	15	50	100
65を超え 100以下 65 exceeded 100 or less	15	50	100

LB型 LB Type

測定ヘッドの先端にあるタイプがLB型となります。

LB type is the type with position of carbide ball in the top of the jet.

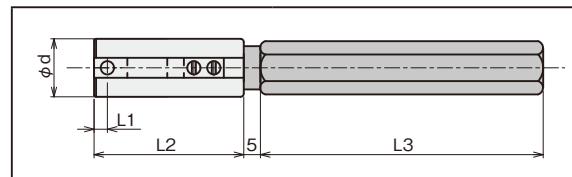

呼び寸法 φd 超え～以下 Nominal Size φd exceeded ~ less	L1	L2	L3
10を超え 14以下 10 exceeded 14 or less	4	45	95
14を超え 20以下 14 exceeded 20 or less	4	45	85
20を超え 24以下 20 exceeded 24 or less	4	45	85
24を超え 40以下 24 exceeded 40 or less	4	45	85
40を超え 50以下 40 exceeded 50 or less	4	50	100
50を超え 65以下 50 exceeded 65 or less	4	50	100
65を超え 100以下 65 exceeded 100 or less	4	50	100

- ハンドルタイプのエアマイクロメータ用内径測定子で深穴等を測定したい時は、中間シャクを接続することにより簡単に首下を長くすることができますので、必要に応じお申し出下さい。
(中間シャクで対応できる穴径はφ11を超えるサイズとなります)

- For measuring such deep holes using handle type air jet for air micrometer, the neck of air jet can be lengthened by connecting a center shank. Please notify us when you have request on this matter. (Note: The hole diameter that can be coped with by the center shank is beyond φ 11 mm)

AIR GAUGE

エアゲージ

VC型外径測定子

Air Jet VC Type for Outside Diameter

ワークをはさんで外径測定するハサミ式の測定子です。ワークを受けるVブロック面には耐摩耗性を高めるため超硬チップを貼り付けてあります。

It is snap type for measuring outside diameter by inserting the workpieces to the V block side. The carbide chip is set on V block side to improve wear resistance.



VC型 VC Type

呼び寸法 D 超え～以下 Nominal Size D exceeded ~ less	A	B	L
4を超え 10以下 4 exceeded 10 or less	38	47	90
10を超え 14以下 10 exceeded 14 or less	42	50	90
14を超え 24以下 14 exceeded 24 or less	D+30	68	90
24を超え 40以下 24 exceeded 40 or less	D+30	73	90
40を超え 55以下 40 exceeded 55 or less	D+30	73	90
55を超え 70以下 55 exceeded 70 or less	D+30	76	110

OR型外径測定子

Air Jet OR Type for Outside Diameter

ワークをリング式測定子の中に入れて外径を測定します。比較的小径のワーク測定に使われます。

The workpieces are inserted to the ring type of air jet and their outside diameters are measured. It is used for measuring the workpieces having a relative small diameter.



LV型外径測定子

Air Jet LV Type for Outside Diameter

コンタクトリーフ（板バネ）の測定ポイント部に超硬ボールを用い測定する接触式測定子がLV型外径測定子です。主に測定面の幅が5mm以下または、表面粗さが6Sより粗い場合に用いられます。

It is a contact type of VC jet for measuring outside diameter of the workpieces having surface roughness more than 6S or width of the measured surface less than 5 mm.

The carbide ball is set on the measuring point of the contact leaf (blade spring).

LV型 LV Type

呼び寸法 D 超え～以下 Nominal Size D exceeded ~ less	A	B	L
4を超え 10以下 4 exceeded 10 or less	38	47	90
10を超え 14以下 10 exceeded 14 or less	42	50	90
14を超え 24以下 14 exceeded 24 or less	D+30	68	90
24を超え 40以下 24 exceeded 40 or less	D+30	73	90
40を超え 55以下 40 exceeded 55 or less	D+30	73	90
55を超え 70以下 55 exceeded 70 or less	D+30	76	110

LR型外径測定子

Air Jet LR Type for Outside Diameter

コンタクトリーフ（板バネ）の測定ポイント部に超硬ボールを用い測定するリング形状の接触式測定子がLR型外径測定子です。主に測定面の幅が5mm以下または、表面粗さが6Sより粗い場合で比較的小径のワーク測定に使われます。なお、最小寸法はφ10mmを超えるサイズとなります。

It is contact type of OR jet for measuring outside diameter of the workpieces having surface roughness more than 6S or surface width to be measured less than 5 mm. The carbide ball is set on the measuring point of the contact leaf (blade spring).

This type is commonly used for measuring a relatively small diameter.

The smallest diameter which can be measured is φ10mm.

OR型 OR Type

呼び寸法 φD 超え～以下 Nominal Size φD exceeded ~ less	φA	T	L1	L2
4を超え 10以下 4 exceeded 10 or less	53	18	156	110
10を超え 14以下 10 exceeded 14 or less	53	18	156	110
14を超え 20以下 14 exceeded 20 or less	63	24	164	110
20を超え 30以下 20 exceeded 30 or less	71	24	167	110
30を超え 40以下 30 exceeded 40 or less	85	24	180	110
40を超え 50以下 40 exceeded 50 or less	100	24	213	130
50を超え 60以下 50 exceeded 60 or less	112	24	222	130

AIR MICROMETER

AIR GAUGE

GAUGE

空気マイクロメータ用マスターゲージ Master Gauges for Air Micrometer

比較測定および測定子の調整用にマスターゲージが必要となります。
経年変化の心配のないサブゼロ処理を施した高精度のマスターゲージを供給いたします。

The master gauges are used for adjusting comparator type measuring instrument and air jet.
We provide master gauges with high accuracy produced using zero treatment for preventing the gauges from secular distortion.



マスターリングゲージ Master Ring Gauge

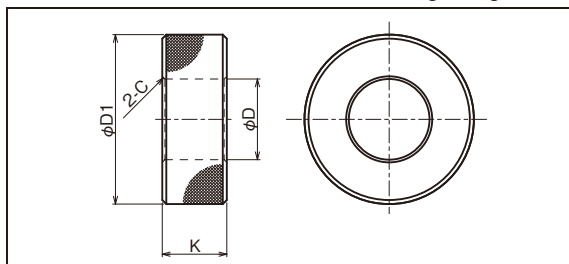

呼び寸法 φD 超え～以下 Nominal Size φ D exceeded ~ less	φD1	K	C面取り Chamfering
3～ 5	22	6	0.3
5～ 10	32	8	0.5
10～ 15	38	10	0.5
15～ 20	45	12	1.0
20～ 25	53	14	1.0
25～ 32	63	16	1.0
32～ 40	71	18	1.0
40～ 50	85	20	1.0
50～ 60	100	24	1.5
60～ 70	112	24	1.5
70～ 80	125	24	1.5
80～ 90	140	24	1.5
90～100	160	24	1.5

マスタープラグゲージ Master Plug Gauge

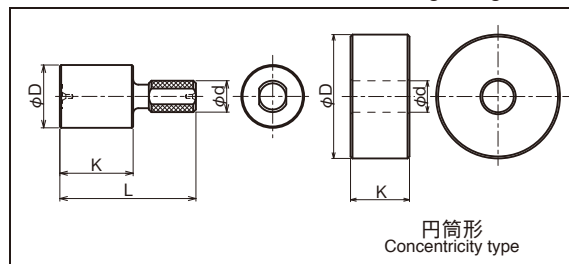

呼び寸法 φD 超え～以下 Nominal Size φ D exceeded ~ less	K	L	φ d
3～ 6	12	26	6
6～ 10	16	30	7
10～ 14	20	38	8
14～ 18	24	44	10
18～ 24	28	52	12
24～ 30	32	58	15
30～ 40	36	68	18
40～ 50	42	78	22
50～ 65	30	—	16
65～ 80	30	—	16
80～100	36	—	20

注文時の留意点 Ordering instructions

- ご注文の際にエアマイクロメータ本体のメーカー名・型式・使用倍率をお申し出下さい。
- 測定寸法、許容公差および表面粗さをお申し出いただくか、ワーク図を支給願います。
- 調整用に必ずマスターゲージ1セット（大範・小範）が必要となります。
マスターゲージは製作納入か、お客様より支給されるかをお申し出下さい。
- 使用本体・使用倍率をご不明のときは、ワーク図を頂ければご相談に応じます。
- Please specify the manufacturer name, the model, and the magnification of the air micrometer when ordering.
- Please specify the size, the limit deviation tolerance and the surface roughness of the workpieces or provide the figure of the workpieces.
- A set of master gauge (maximum and minimum size) is required by all means for adjustment.
Please specify whether the master gauge is provided by our production delivery or by yourself.
- We respond to the consultation if you are not sure about the manufacturer name and magnification of the air micrometer used.
In this case, the figure of the workpieces should be attached.



AIR MICROMETER

AIR GAUGE

GAUGE

GAUGE

ねじ用限界ゲージ

Limit Gauges for Screw Threads

ねじ用限界ゲージは、ねじ規格と同じ等級に定められ、それに対応したねじ用限界ゲージを使用します。検査の方法は生産される各部品の許容限界寸法の上限、下限の許容差内にあるかをGO, NOT GOの限界方式のゲージを用いて検査します。

The limit gauges for screw threads are provided in the same class with the screw standard and are used for the corresponding screws.

By using GO and NOT GO limit gauges, the workpieces produced are inspected for assuring whether their limit size are within upper and lower of the limit deviation tolerances or not, respectively.

平行ねじ用限界ゲージ Limit Gauges for Parallel Screw Threads



メートルねじ、ユニファイねじ、自転車ねじ、マシンねじ等、種々のねじに対応したねじ用限界ゲージをお使い下さい。限界方式は大きく分けてISO導入JIS規格と従来JIS規格（検査用・工作用）があります。

JIS規格ではおねじの外径をプレーンリングゲージまたはプレーンハサミゲージ、めねじ内径はプレーンプラグゲージを用いて検査することを原則として定めています。

以上のゲージを使用することにより、ねじの複雑な要素を簡単に手早く検査できるため量産品の品質管理には最適です。

Please use the thread limit gauges corresponding to various screws such as meter screw, bicycle screw, unified screw, sewing machine screw, etc.

The limit gauges are divided into ISO-based JIS and conventional JIS (for inspection and production use).

According to JIS, outside diameter of the male screws are basically measured using plain ring gauge or snap gauge and inside diameter of female screws are measured using plain plug gauge.

By using such the gauges, the complex element of the screw can be inspected easily and quickly.

Therefore, such the gauges are effective to control the quality of the workpieces in mass-production line.

標準ねじゲージ Standard Thread Gauges

標準ねじゲージとは、ねじプラグゲージとねじリングゲージとがしっかりと嵌合する一対のねじゲージです。

それぞれねじの要素は、ねじの基準山形に極めて近く作られています。

このゲージはJIS規格には規定されておりませんが、普通多量生産用に使われている限界ねじゲージとは異なり、高精度のはめあいを要求する少量のねじの検査に適します。

被チェックねじは、できるだけねじゲージにしっかりとしたはめあい状態にするのが望ましいとされています。

The standard thread gauge is a couple of thread gauges consisted of thread ring gauge and thread plug gauge that fits perfectly.

The elements of the screwed parts are made extremely similar to the basic profile of the screw thread.

This gauge is not specified in JIS and differs from limit thread gauges usually used in mass-production line.

These gauges are suitable for inspecting small amount of screws which must be engaged perfectly.

The screws to be checked should be fitted perfectly as much as possible to the thread gauges



管用ねじゲージ

Gauges for Pipe Threads

管用平行限界ねじゲージ Limit Gauges for Parallel Pipe Threads

G (ISO導入JIS規格) ISO-based JIS



JIS規格に制定された管用平行ねじ (G) は、耐密性を必要としない機械的結合を主目的とする管、管用部品、流体機器などの接続に用いられ、管用平行限界ねじゲージ (G) は同上ねじ部の寸法の検査に用います。

Parallel pipe threads (G) specified in JIS are used to connect fluid equipments, plumbing parts, pipes where density resistance is unnecessary in their mechanical connection.

Limit gauges for parallel pipe threads (G) are used for inspecting the dimension of such the threads.

- めねじ用のねじプラグゲージには等級はありません。
- おねじ用のねじリングゲージにはA級、B級の等級があります。
- ただし、通り側 (GR) ゲージのみはA級、B級において共用です。
- There is no grade in the plug gauges for female screw threads.
- The grade of class A and class B are for ring gauges of male screw threads.
- However, class A and class B are common for GO sides of gauges (GR) only.

PF (ISO導入JIS規格) ISO-based JIS

ねじプラグゲージ Thread Plug Gauge

PF (従来JIS規格) Conventional JIS

ねじリングゲージ Thread Ring Gauge



JIS規格 (付属書) に規定している管用平行ねじ (PF) は、耐密性を必要としない機械的結合を目的とする管、管用部品、流体機器などの接続に用いられ、管用平行限界ねじゲージ (PF) は同上ねじ部の寸法検査に用います。

Parallel pipe threads (PF) specified in JIS are used to connect fluid equipments, plumbing parts, pipes where density resistance is unnecessary in their mechanical connection.

Limit gauges for parallel pipe thread (PF) are used for inspecting the dimension of such the threads.

- ねじの等級はA級、B級の二つがあり、検査用、工作用のゲージがあります。
- ただし、通り側 (プラグ・リング) ゲージのみはA級、B級において共用です。
- The screw threads have two classes of class A and class B. There are gauges for inspection and production use. However, class A and class B are common for GO sides (plug/ring) of gauges only.

GAUGE

管用テーパねじゲージ

Gauges for Taper Pipe Threads

R (ISO導入JIS規格) ISO-based JIS

JIS規格に制定された管用テーパねじ (R) は、管、管用部品、流体機器などの接続において、ねじ部の耐密性を主目的としています。

管用テーパねじゲージ (R) は、同上ねじ部の寸法検査に用います。

Taper pipe threads (R) specified in JIS are purposed mainly to increase the density resistance of the screwed parts when connecting the fluid equipments, plumbing parts and pipes. The gauges for taper pipe threads (R) are used for inspecting dimension of such the threads.



ねじ & ゲージの種類と記号 Type and Marks of Threads and Gauges

検査されるねじ Thread to be inspected	ねじ用ゲージの種類 Type of Thread Gauge	ゲージの点検に用いるゲージ Gauges for inspecting gauges
管用テーパおねじ (R) Male Taper Pipe Thread (R)	テーパねじリングゲージ (R) Taper Thread Ring Gauge (R)	テーパねじリングゲージ (R) 用点検プラグ (CP) Inspection Plug (CP) for Taper Thread Ring Gauge (R)
管用テーパめねじ (Rc) Female Taper Pipe Thread (Rc)	テーパねじプラグゲージ (R) Taper Thread Plug Gauge (R)	—
管用平行めねじ (Rp) Female Parallel Pipe Thread (Rp)		

注) 管用平行めねじは管用テーパおねじに対して使用するもので、管用平行めねじ (G) または (PF) とは寸法許容差が異なります。

Note: Female parallel pipe threads are used for male taper pipe threads. Their limit deviation tolerances are different from the female parallel pipe threads (G) or (PF).

PT (従来JIS規格) Conventional JIS

JIS規格 (付属書) に規定している管用テーパねじ (PT) は耐密性を必要とする管、管用部品、流体機器などの接続に用いられ、管用テーパねじゲージ (PT) は、同上ねじ部の寸法検査に用います。

Taper pipe threads (PT) specified in JIS are used to connect fluid equipments, plumbing parts, pipes where density resistance is necessary for their mechanical connection. The gauges for taper pipe threads (PT) are used for inspecting the dimension of such the threads.



ねじ & ゲージの種類と記号 Type and Marks of Threads and Gauges

検査されるねじ Thread to be inspected	ねじ用ゲージの種類 Type of Thread Gauge	備考 Remarks
管用テーパおねじ (PT) Male Taper Pipe Thread (PT)	テーパねじリングゲージ (PT) Taper Thread Ring Gauge (PT)	テーパねじプラグとリングゲージはセットになります。 Taper Thread Plug and Ring Gauge is a set
管用テーパめねじ (PT) Female Taper Pipe Thread (PT)	テーパねじプラグゲージ (PT) Taper Thread Plug Gauge (PT)	
管用平行めねじ (PS) Female Parallel Pipe Thread (PS)		

注) 管用平行めねじは管用テーパおねじに対して使用するもので、管用平行めねじ (G) または (PF) とは寸法許容差が異なります。

Note: Female parallel pipe threads are used for male taper pipe threads. Their limit deviation tolerances are different from the female parallel pipe threads (G) or (PF).

管用テーパねじとテーパねじゲージの使い方と関係

The Relationship between the Taper Pipe Threads and the Taper Pipe Thread Gauges and their Use

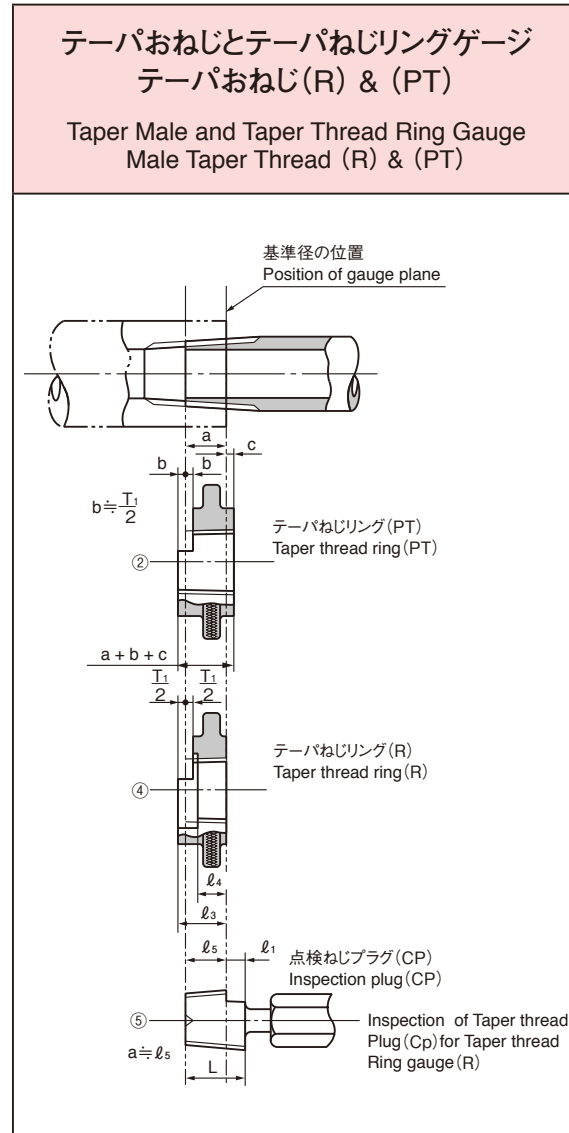
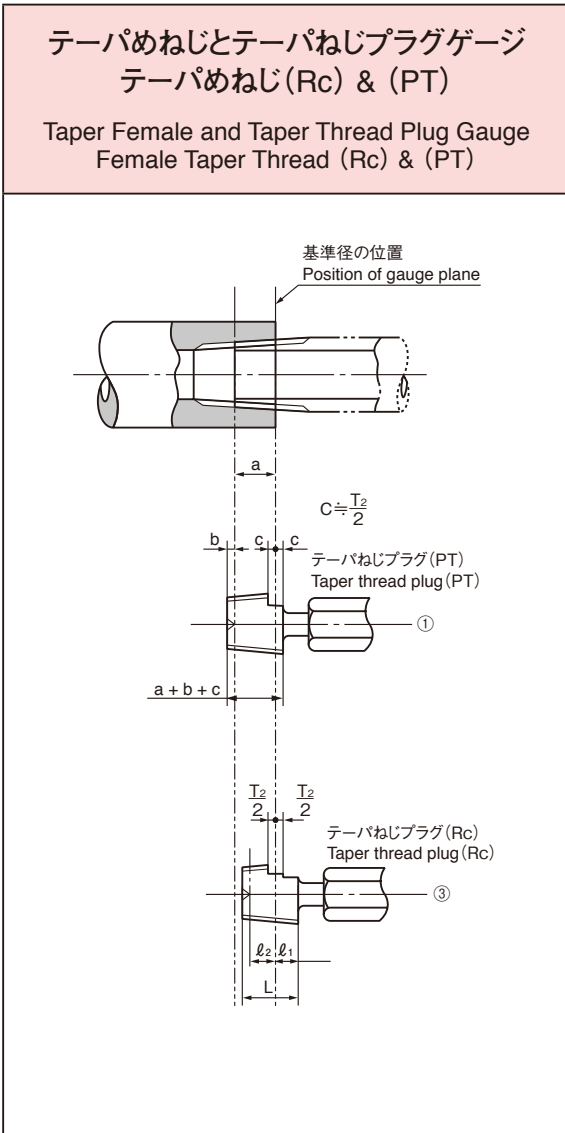

管端部のテーパおねじと継手端部のテーパめねじとが、規定を満たしてはめ合うかどうかをテーパねじゲージを用いて検査を行います。

ゲージは被検査ねじに手締め状態ではめ合わせると必ず止ります。従来JIS規格(PT)では、テーパねじプラグ①をはめ込んだ時ノッチ(切欠き)2cの範囲に継手のテーパめねじ端部が位置すれば合格と判定します。

テーパねじリング②を管のテーパおねじにはめ込み2bのノッチ範囲に管端が位置すれば合格と判定します。

ISO導入JISのテーパねじプラグ(R)③を用いて行う場合は、継手のテーパめねじ端部はT2の範囲に位置すれば合格またテーパねじリング(R)④では管のテーパおねじ端部がT1の範囲に位置すれば合格とそれぞれ判定します。

なお点検プラグ(CP)⑤は、テーパねじリング(R)④の有効径が規定の摩耗限界を超えているかどうかを確認するために使用します。

The taper thread plug gauges are used to inspect whether the male taper thread of the pipe and the female taper thread of the coupling meets specifications or not when they are fitted. The gauge should stop by all means when it is fitted to the threads to be inspected.

According to conventional JIS (PT), the female taper thread is judged pass when the inserted taper thread plug ① stopped within the range of notch 2c. Similarly, the male taper threads are judged pass when the inserted taper thread ring ② stopped within the range of notch 2b. In case of using taper thread plug (R) of ISO-based JIS ③, the female taper threads are judged pass when the end of inserted taper thread plug stopped within the range of T2. And the male taper threads are judged pass when the inserted taper thread ring (R) ④ stopped within the range of T1.

The inspection plugs (CP) ⑤ are used to confirm whether the effective diameter of taper thread ring (R) ④ exceeds the specified wear limit or not.

GAUGE

NPT National Pipe Taper

アメリカ規格(ANSI)に規定されている管用テーパねじ NPTは管、管用部品、流体機器などの接続に用いられねじ部の耐密性を主目的としています。

管用テーパねじゲージ(NPT)は、同上ねじ部の寸法検査に用います。

Taper pipe threads (NPT) specified in American standard (ANSI) are used to connect pipes, plumb parts, fluid equipments, etc and are purposed to increase the density resistance of the threaded parts.

Gauges for taper pipe threads (NPT) are used for measuring dimension of such the threads.



管用テーパねじとテーパねじゲージ(NPT)との関係 Relationship between Taper Pipe Thread and Taper Pipe Thread Gauges (NPT)

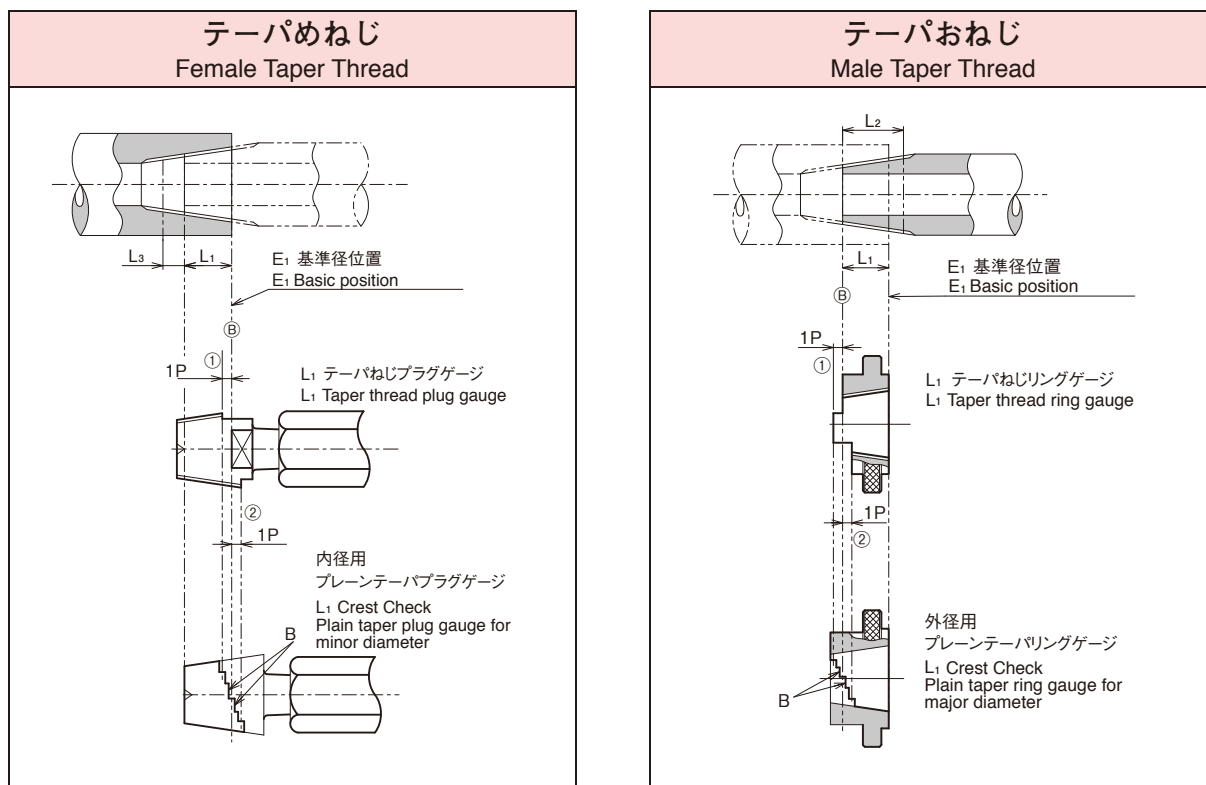

テーパねじゲージ(NPT)は種々のノッチ(切り欠き)を持つゲーjing方式がありますが、一般的には①最小限界位置、②基準径位置、③最大限界位置の3段ノッチを持つL1テーパねじゲージが多く使われています。

同上ゲージの使い方は前述したとおりですが、外・内径のねじ山高さにトランケーションの規定がありますので、6段ノッチを持つプレーンテーパゲージを用いて、ねじの外・内径の検査を行うことをお勧めします。

まず、テーパねじの有効径寸法をテーパねじゲージで検査し、例えば③基準径位置に近接して合格した場合は、ねじの外・内径検査においてもプレーンテーパゲージのノッチ、Bの限界範囲に管の末端があれば合格とします。

There are many types of gauges for taper threads (NPT) with various different notches. In general, the gauges for taper threads L1 having 3-step notches, i.e., minimum limit position ①, basic position ③ and maximum limit position ②, are the most commonly used. The use of the taper thread gauges has been explained in the previous pages.

However, since there is a specification of truncation for major and minor diameters of thread height, it is recommended to measure major and minor diameters using plain taper gauge having 6-step notches.

First, the pitch diameter of the taper thread is measured with a taper thread gauge. For example, when it is judged pass at near the notch of basic position ③, then for major and minor diameters, is also similar. That is the item is judged pass when the pipes can go within limit range of B.

NPTF National Pipe Taper Fuel and Oil

アメリカ規格 (ANSI) に規定されている管用テーパねじ NPTFは管、管用部品、流体機器などの接続に用いられ、普通シールコンパウンドは使わずともねじ部の高耐密性を得ることができます。

管用テーパねじゲージ (NPTF) は、同上ねじ部の寸法検査に用います。

Taper pipe threads NPTF specified in American standard (ANSI) are used to connect fluid equipments, plumb parts, pipes. The density resistance of the thread parts can be obtained even without using seal compound.

Gauges for taper pipe threads (NPTF) are used to check the dimension of such the threads.



管用テーパねじとテーパねじゲージ (NPTF) との関係

Relationship between dryseal Taper Pipe Thread and dryseal Taper Pipe Thread Gauges (NPTF)

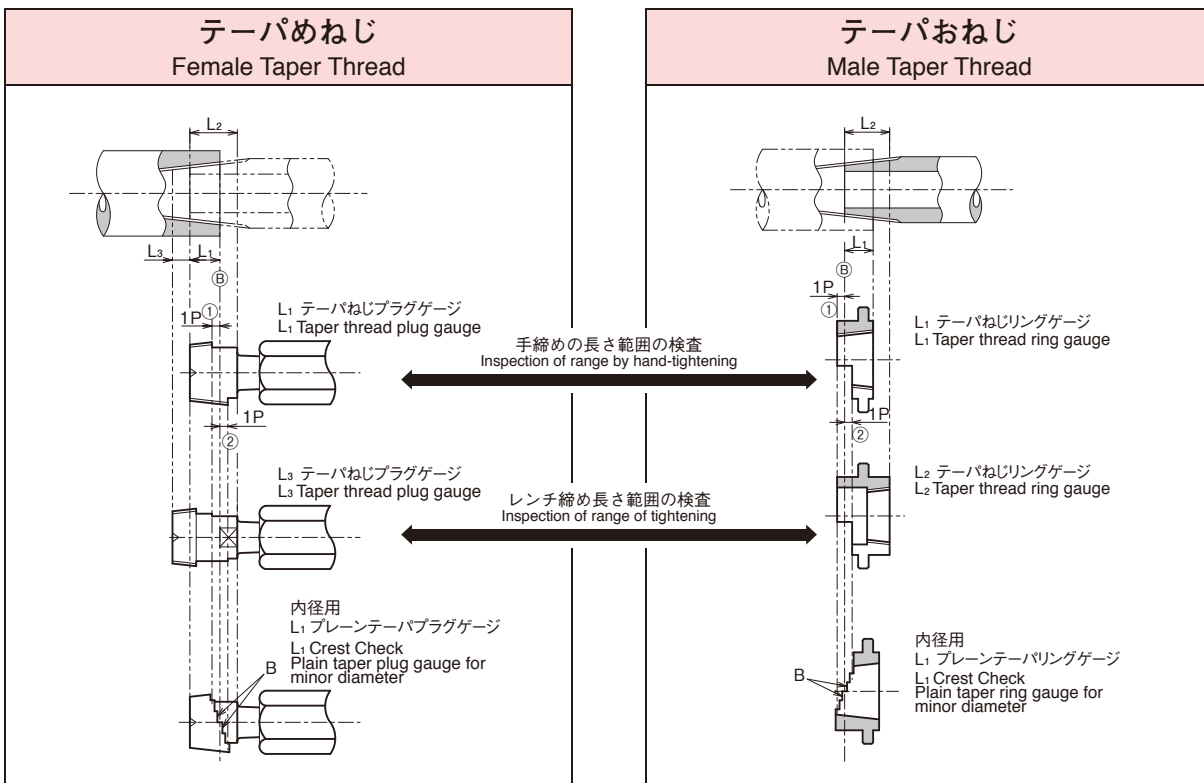

テーパねじゲージ (NPTF) は種々のノッチ (切り欠き) を持つゲージング方式がありますが、当社では①最小限界位置、②最大限界位置の2段階ノッチを持つL1テーパねじゲージを採用しています。(この他に3段階、4段階タイプも製作できます)

テーパおねじ、めねじの山高さにトランケーションの規定があるのはNPTと同様で、6段階ノッチを持つブレンテーパゲージを用いて、ねじの外・内径の検査を行うことをお勧めします。なお、手締め長さ範囲 (Handtight Engagement) のねじ検査には、めねじはL1テーパねじプラグゲージ、おねじはL1テーパねじリングゲージをそれぞれ用います。また、レンチ締め長さ範囲 (Wrench Allowance) のねじ検査には、めねじはL3テーパねじプラグゲージ、おねじはL2テーパねじリングゲージをそれぞれ用いて検査を行います。

There are many types of gauges for taper threads (NPTF) with various different notches. The gauges for taper threads L1 having 2-step notches, i.e., minimum limit position ① and maximum limit position ②, are used at OJIYA SEIKI. (3-step, 4-step types are also produced upon request.)

Similar to NPT type, it is recommended to measure major and minor diameters using plain taper gauge having 6-step notches. For inspection of thread of handtight engagement, taper thread plug gauge L1 and taper thread ring gauge L1 are used for measuring the female and male threads, respectively.

For inspection of thread of wrench tolerances, taper thread plug gauge L3 and taper thread ring gauge L2 are used for measuring the female and male threads, respectively.

ゲージ

AIR MICROMETER

AIR GAUGE

GAUGE

限界プレーンゲージ

Plain Limit Gauges

限界プレーンゲージとは、穴と軸のはめ合いの互換性を得るために穴または軸の最大許容寸法および最小許容寸法を基準とした測定端面を持つ一対のゲージのことです。

ゲージの許容差、等級は、適用する穴または軸の等級と限界プレーンゲージの種類に応じて規定されています。主な種類としてはプラグゲージ(栓ゲージ)、リングゲージハサミゲージ等があります。

Plain limit gauge is a couple of gauges having measurement side with the maximum and minimum limit deviation tolerance of hole and shaft to assure the interchangeability of the engagement of hole and shaft.

The limit deviation tolerances and the grade of the gauges are determined according to the types of plain limit gauges and applied grade of the hole or the shaft.

The major types are plug gauge (stopping gauge), ring gauge and snap gauge.



限界プラグゲージ Limit Plug Gauges

テーパロック型 Taper Lock Type

1以上2以下 1 include or 2 less

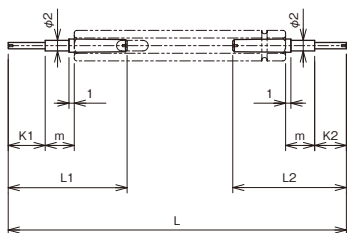

2を越え6以下 2 exceeded or 6 less

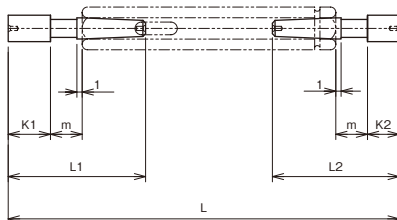

6を越え50以下 6 exceeded or 50 less

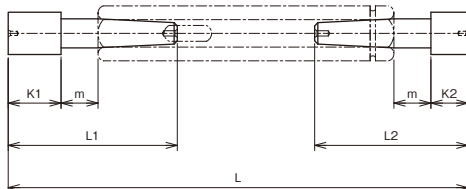

呼び寸法 φd Nominal Size φd 超え～以下 exceeded～less	通 GO		止 NOT GO		首下 Under Neck	全長 Length	ハンドル長さ Handle Length
	K1	L1	K2	L2	m	L	
1以上～2以下 1 include～2 less	6.5	22	4.5	20	5.5	62	40
2～3	6.5	22	4.5	20	5.5	62	40
3～6	8	26	6	24	6	74	48
6～8	10	32	7	29	7	87	56
8～10	10	32	7	29	7	87	56
10～14	12	40	8	36	8	99	63
14～18	16	48	10	42	10	116	70
18～24	16	52	12	48	12	132	80
24～30	18	54	14	50	12	136	80
30～40	20	60	16	56	15	156	90
40～50	25	65	18	58	15	163	90

トリロック型 Trilock Type

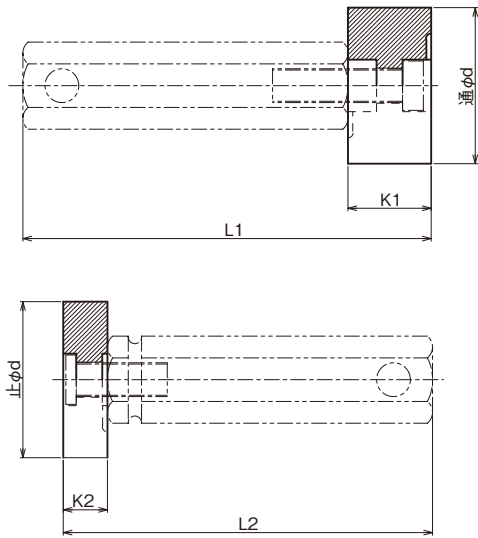

呼び寸法 φd Nominal Size φd 超え~以下 exceeded~less	通 GO		止 NOT GO		ハンドル長さ Handle Length
	K1	L1	K2	L2	
50~ 65	32	155	18	141	125
65~ 80	35	173	25	168	150
80~ 90	35	173	25	168	150
90~ 95	35	173	25	168	150
95~100	35	173	25	168	150
100~110	35	173	25	168	150
110~120	40	178	25	168	150

超硬ゲージ Carbide Gauges

超硬材質のプラグゲージ・リングゲージ・ハサミゲージも製作しています。

The plug gauge, ring gauge, snap gauge using the superhardened materials are produced as well.



限界リングゲージ Limit Ring Gauges

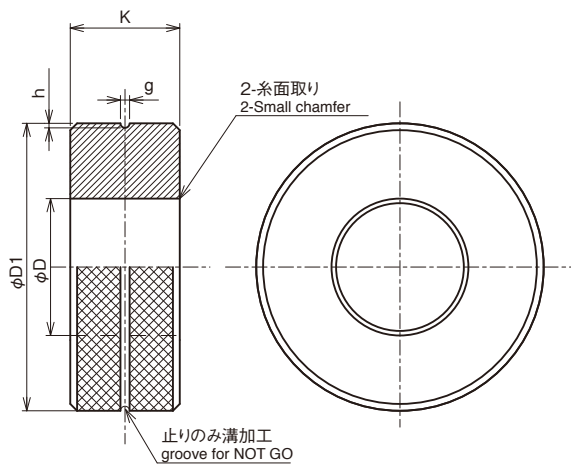

呼び寸法 φD Nominal Size φD 超え~以下 exceeded~less	外径D1 Outside diameter	厚さK Thickness	止め側表示溝 NOT GO side indication	
			g	h
5~ 10	32	8	1	0.8
10~ 15	38	10	2	1
15~ 20	45	12	2	1
20~ 25	53	14	2	1
25~ 32	63	16	2	1
32~ 40	71	18	3	1.5
40~ 50	85	20	3	1.5
50~ 60	100	24	3	1.5
60~ 70	112	24	3	1.5
70~ 80	125	24	3	1.5
80~ 90	140	24	3	1.5
90~100	160	24	3	1.5

GAUGE

ハサミゲージ Snap Gauges

片口板挟みゲージ Single-Ended Snap Gauge

3以上 30以下 3 include 30 or less

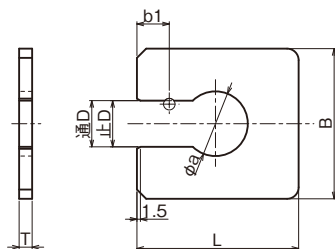

30を超え 50以下 30 exceeded 50 or less

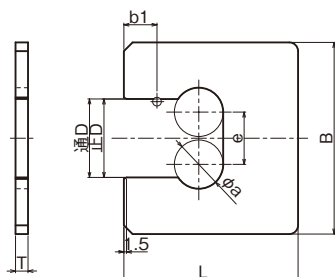

C型板挟みゲージ C Type Snap Gauge

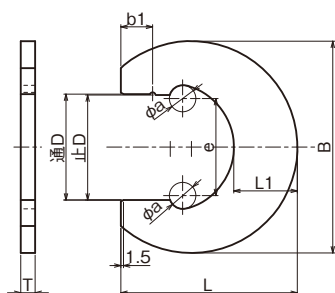

両口板挟みゲージ Double-Ended Snap Gauge

1以上 14以下 1 include 14 or less

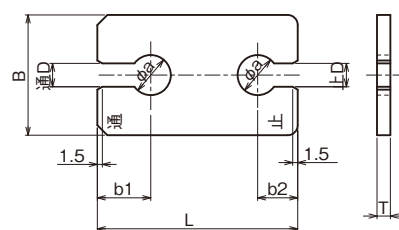

14を超え 50以下 14 exceeded 50 or less

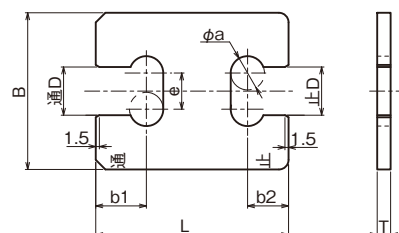

呼び寸法 D Nominal Size D 超え～以下 exceeded～less	B	L	T	φ a	b1	e
3以上～6以下 3 include～6 less	30	50	4	11	10	—
6～10	36	60	4	12	11	—
10～14	50	60	4	18	12	—
14～18	60	70	4	25	13	—
18～24	65	70	4	28	14	—
24～30	75	80	5	34	15	—
30～40	90	90	5	22	17	24
40～50	110	100	5	28	19	30

呼び寸法 D Nominal Size D 超え～以下 exceeded～less	B	L	T	L1	φ a	b1	e
50～ 65	120	100	6	36	15	18	55
65～ 80	142	114	6	41	18	19	69
80～100	162	130	6	45	20	20	88
100～120	192	150	8	51	22	22	106
120～140	218	164	8	54	22	23	126
140～160	236	180	8	58	25	24	143
160～180	258	195	8	60	25	25	163

呼び寸法 D Nominal Size D 超え～以下 exceeded～less	B	L	T	b1	b2	φ a	e
1以上3以下 1 include～3 less	25	50	3	11	8	8	—
3～ 6	30	50	4	14	10	11	—
6～10	36	60	4	16	12	12	—
10～14	50	70	4	18	14	18	—
14～18	60	80	4	21	17	13	14
18～24	65	80	4	21	17	14	15
24～30	75	90	5	23	18	18	19
30～40	90	110	5	28	20	23	24
40～50	110	120	5	32	22	30	31

両口板挟みゲージはご注文の際、別途ご指示がある場合に限り製作いたします。

The double-ended snap gauges are produced only when there is a separate instruction when ordering.

マスターゲージ

Master Gauges

マスターゲージは比較測定器(シリンダーゲージ、内側マイクロメータ、空気マイクロメータなど)の寸法設定および点検管理のための基準ゲージとして用いられます。

Master gauges are used as a standard gauge for calibrating, checking and maintaining comparator type measuring instruments, such as cylinder gauges, micrometers, air micrometers, etc.



スプラインゲージ

Spline Gauges

スプラインは回転軸と部品の結合に用いられるもので、スプライン部を検査するためスプラインゲージが多く使用されます。

スプラインゲージはプラグゲージのほかリングゲージも製作いたします。

Splined parts are used in joining part between rotation axis and the part. Spline gauges are used to inspect such the splined parts. We produce plug type and ring type of spline gauges.

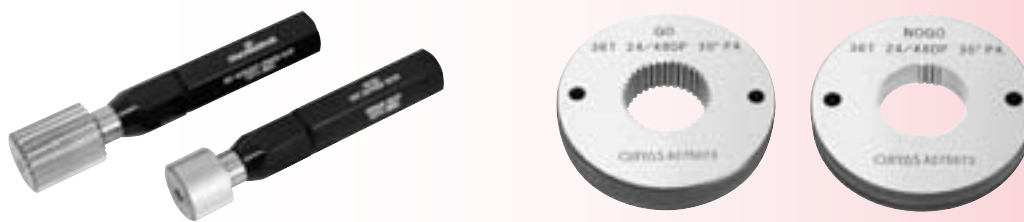

テーパゲージ

Taper Gauges

テーパゲージは各種機械部品、工具などのテーパ部の角度、円すい直径を検査し、製品の互換性を得るために用いられます。旋盤、ボール盤、研削盤の主軸穴、芯押台のセンター穴またはドリル、リーマのシャンク部、ソケットなどのテーパは一般的にモーステーパ(MT)が使用されます。

ナショナルテーパ(NT)はフライス盤などの主軸穴およびBT切削工具に用いられ、ジャコブステーパ(JT)はドリルチャックなどに使用されています。

テーパプラグゲージの基準位置には画線が設けてあり、製品のテーパ検査ではブルーペーストをごく薄く塗り、ゲージまたは製品の一方を固定し、両者を確実にはめ合わせた後、45°程度静かに回転させる。そして回転させないように注意深く抜き取ります。その当り状態の比較(%)で判定を行います。

Taper gauges are used for inspecting the angle of taper or cone diameter so as to secure interchangeability of products.

In most cases, Morse Taper (MT) is used for the main spindle bore of lathes, drilling machines and for the locating bore of taper shank drills, taper shank reamers and machining centers.

National Taper (NT) is used for the main spindle bore of milling machines, NC machining centers, and BT cutting tools. Jacobs Taper (JT) is used for drill chucks, etc.

The basic position of taper plug gauge is indicated by an etched line. After applying a blue paste to the surface of the taper gauge, the gauge is inserted into the taper bore, pushed firmly into position and slowly rotated 45 degree. Then the taper gauges is carefully removed without twisting.

The percentage of area touching the opposing surface can be determined by observing the color pattern.



GAUGE

特殊ゲージ Special Gauges

直角度用ゲージ Gauge for Perpendicularity

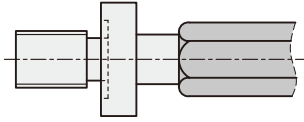

めねじ用(ツバ付きゲージ)
For female thread
(Gauge with flange)

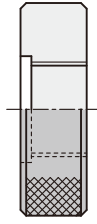

おねじ用
For male thread

製品ねじと端面の直角度を判定するゲージです。ゲージをねじ込んだ際、ワークの端面にゲージの端面が密着すればワークは良品と判定されます。

It is the gauge for checking perpendicularity of the threaded parts of the workpieces and the edge.

When the gauge is inserted and the edge of the workpieces fitted perfectly with the edge of the gauges, the workpieces are judged qualified.

深穴用ゲージ Gauge for Deep Holes

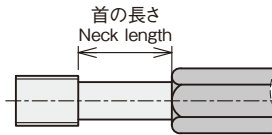

めねじ用(首長ゲージ)
For female thread
(Neck length gauge)

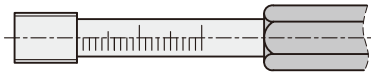

めねじ用(首長ゲージ目盛り付き)
For female thread
(Neck length gauge with scale)

製品ねじが端面より深い位置にある場合は、深穴用ゲージを使用します。

ネックに設けた目盛によって深さを読み取ることもできます。

This gauge is used for the workpieces with threaded parts located deeper from the edge. The depth can be read using the scale on the neck.

有効ねじ長さ用ゲージ Gauge for Effective Thread Length

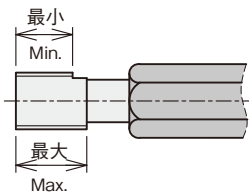

めねじ用
For female thread

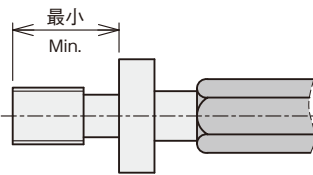

めねじ用
For female thread

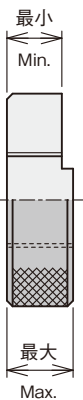

おねじ用
For male thread

製品ねじの有効長に公差がある場合は、有効ねじ長さ用ゲージを使用します。切欠やツバの端面までの位置で合否の判定をします。

This gauge is used for the workpieces having tolerances in their effective length of the threaded parts.

The workpieces are judged pass by considering the position of notch.

同軸度用ゲージ Gauge for Concentricity

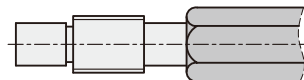

めねじ用
For female thread

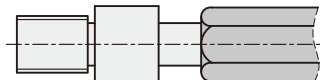

めねじ用
For female thread

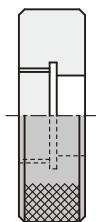

おねじ用
For male thread

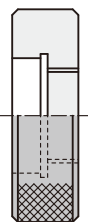

おねじ用
For male thread

製品のねじの穴または軸に対する同軸度を判定するゲージです。

ゲージが挿入されることにより製品が良品と判定されます。

It is used to measure the concentricity of the hole or shaft of the threaded parts of workpieces.

The workpieces are measured by inserting the gauge.

目盛付ねじ深さゲージ

Thread Depth Gauge with Graduation Scale

M2～M18までの有効径検査と同時に完全ねじ部の深さを検査できます。

標準タイプ DSG とハイスぺックタイプ DSG-HS の2種類があります。

It can inspect both of the pitch diameter and depth of the completed thread (M2 to M18).

Standard type DSG and high spec type DSG-HS are available.

DS Gauge-HS (ハイスぺックタイプ)

DS Gauge-HS (High Spec Type)

専用ねじゲージおよび下孔用栓ゲージを使用することにより深さ測定範囲が広がりました。深さ読み取りが0.1mm単位で読み取ることができます。

通りゲージのみのご注文にも対応致します。

The special thread gauge and plain gauge for thread hole is used in this type and the depth range is wider. The depth of the thread can be read with 0.1mm increment.

The purchase for gauge of GO side only is also available.



ホルダーNo Holder No	ねじサイズ Thread size	深さ測定範囲 Depth range	φA	L	(B)	φD	質量 Weight
DSG-HS1	M 2～M3.5	2～14mm	10	97	19	16	50g
DSG-HS2	M 4～M 6	3～26mm	12	115	32	18	80g
DSG-HS3	M 7～M 10	5～45mm	15	132	51	21	180g
DSG-HS4	M11～M 14	5～45mm	20	133	51	28	350g
DSG-HS5	M15～M 18	10～60mm	25	180	71	32	700g

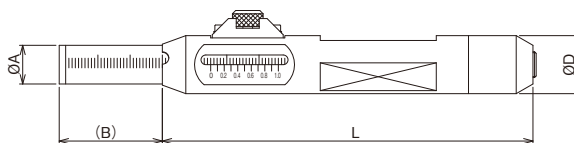

DS Gauge (標準タイプ)

DS Gauge (Standard Type)

標準在庫のねじゲージを使用できるため即納対応となっています。

深さ読み取りが0.5mm単位で読み取ることができます。

Since gauge part of this type uses our stock of standard thread gauges, prompt delivery is ensured. The depth of the thread can be read with 0.5 mm increment.



ホルダーNo Holder No	ねじサイズ Thread size	深さ測定範囲 Depth range	φA	L	(B)	φD	質量 Weight
DSG-1H	M 2～M3.5	2～10mm	8	80	29	17	80g
DSG-2H	M 4～M 6	3～12mm	11	85	33	20	110g
DSG-3H	M 7～M10	5～18mm	16	113	45	26	270g
DSG-4H	M11～M14	5～23mm	20	141	59	30	550g
DSG-5H	M15～M18	10～30mm	24	160	62	36	890g

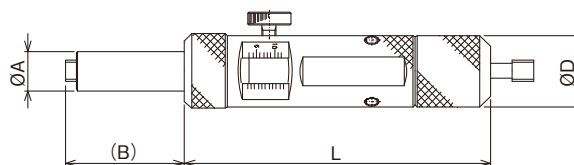

GAUGE

DS Gauge ねじ部交換用オプション型番表

Table of model number for Replacing

ねじサイズ Thread size	DSG-HS Type					DSG type		
	ホルダー型番 Holder No.	セッティングマスター Set Master No.	取り外し工具ねじ用 Removing tool for thread	取り外し工具下孔栓用 Removing tool for plain gauge		ホルダー型番 Holder No.	セッティングマスター Set Master No.	取り外し工具ねじ用 Removing tool for thread
			GO・NO GO	GO	NO GO			GO
M2×0.25	DSG-HS1	HS1M125	RT2025	RPG11	RPN11	DSG-1H	HS1M125	R-1H
M2×0.4		HS1M200	RT2040	RPG12	RPN12		HS1M200	
M2.5×0.45		HS1M225	RT2504	RPG13	RPN13		HS1M225	
M2.6×0.45			RT2604	RPG14	RPN14			
M3×0.35		HS1M175	RT3035				RPG14	
M3×0.5		HS1M250	RT3050	RPG23	RPN23			
M4×0.5	DSG-HS2	HS2M250	RT4050			RPG21	RPN21	DSG-2H
M4×0.7		HS2M350	RT4070	RPG22	RPN22	HS2M350		
M5×0.5		HS2M250	RT5050	RPG23	RPN23	HS2M250		
M5×0.8		HS2M400	RT5080	RPG24	RPN24	HS2M400		
M6×0.75		HS2M375	RT6075	RPG23	RPN23	HS2M375		
M6×1.0		HS2M500	RT6100			HS2M500		
M7×0.75	DSG-HS3	HS3M375	RT7075	RPG30	RPN30	DSG-3H	HS3M375	R-3H
M7×1.0		HS3M500	RT7100				HS3M500	
M8×0.75		HS3M375	RT8075				HS3M375	
M8×1.0		HS3M500	RT8100				HS3M500	
M8×1.25		HS3M625	RT8125				HS3M625	
M9×0.75		HS3M375	RT9075				HS3M375	
M9×1.0		HS3M500	RT9100				HS3M500	
M9×1.25		HS3M625	RT9125				HS3M625	
M10×0.5		HS3M250	RT1005				HS3M250	
M10×0.75		HS3M375	RT1007				HS3M375	
M10×1.0		HS3M500	RT1010				HS3M500	
M10×1.25		HS3M625	RT1012				HS3M625	
M10×1.5		HS3M750	RT1015				HS3M750	
M11×1.0		DSG-HS4	HS4M500				RT1110	
M11×1.5	HS4M750		RT1115	HS4M750				
M12×1.0	HS4M500		RT1210	HS4M500				
M12×1.25	HS4M625		RT1212	HS4M625				
M12×1.5	HS4M750		RT1215	HS4M750				
M12×1.75	HS4M875		RT1217	HS4M875				
M14×1.0	HS4M500		RT1410	HS4M500				
M14×1.5	HS4M750		RT1415	HS4M750				
M14×2.0	HS4M100	RT1420	HS4M100					
M15×1.0	DSG-HS5	HS5M050	RT1510	RPG50	RPN50	DSG-5H	HS5M050	R-5H
M15×1.5		HS5M075	RT1515				HS5M075	
M16×1.0		HS5M050	RT1610				HS5M050	
M16×1.5		HS5M075	RT1615				HS5M075	
M16×2.0		HS5M010	RT1620				HS5M010	
M17×1.0		HS5M050	RT1710				HS5M050	
M18×1.0			RT1810					
M18×1.5		HS5M075	RT1815				HS5M075	
M18×2.0		HS5M100	RT1820				HS5M100	
M18×2.5		HS5M125	RT1825				HS5M125	

ねじ部交換用オプション Option for replacing the thread part

ゲージ取り外し工具 : ゲージ交換時の取り外しに使用します

Gauge removing tool : Used to remove the gauge when the gauge member is changed.

セッティングマスター : ねじゲージの交換時深さセット用に使用します (DSG、DSG-HS共通となります)

Depth setting master : Used to set the depth when the gauge member is replaced.



ねじゲージ取り外し工具
Gauge removing tool



プラグゲージ取り外し工具
Plug Gauge removing tool



簡易セッティングマスター
Depth setting master



ユニバーサルセッティングマスター
Common Depth setting master

ゲージ在庫表

Stock List of Gauges

メートルねじ用限界ねじゲージ在庫表
Stock List of Limit Gauges for Metric Threads

■ねじプラグ・ねじリング共通
Universality of Thread Plug and Thread Ring

●…従来JIS 2級 ●…Conventional JIS Class 2
●…ISO導入JIS 6H・6g相当 ●…ISO-based JIS Class 6H,6g

呼び径 Nominal Diameter	ピッチ Pitch																							
	0.2	0.25	0.3	0.35	0.4	0.45	0.5	0.6	0.7	0.75	0.8	0.9	1	1.25	1.5	1.75	2	2.5	3	3.5	4	4.5	5	
M 1		●●																						
M 1.1																								
M 1.2		●●																						
M 1.4			●●																					
M 1.6				●●																				
M 1.7				●●																				
M 1.8				●●																				
M 2		●●			●●																			
M 2.2		●				●																		
M 2.3					●																			
M 2.5						●●																		
M 2.6						●●																		
M 3				●●			●●																	
M 3.5				●				●																
M 4							●●		●●															
M 4.5							●		●															
M 5							●●					●●												
M 5.5							●																	
M 6							●			●●			●●											
M 7							●			●●			●●											
M 8							●			●●			●●	●●										
M 9							●			●●			●●	●●										
M 10							●			●●			●●	●●	●●									
M 11							●			●			●●	●●	●●									
M 12							●			●●			●●	●●	●●	●●								
M 13							●			●			●●	●●	●●	●●	●●							
M 14							●			●			●●	●	●●		●●							
M 15							●			●			●●	●●	●●	●●	●●							
M 16							●			●			●●	●●	●●	●●	●●	●●						
M 17							●			●			●●	●●	●●	●●	●●	●●						
M 18							●			●			●●	●●	●●	●●	●●	●●	●●					
M 20							●			●			●●	●●	●●	●●	●●	●●	●●	●●				
M 22							●			●			●●	●●	●●	●●	●●	●●	●●	●●				
M 24							●			●			●●	●●	●●	●●	●●	●●	●●	●●	●●			
M 25							●			●			●●	●●	●●	●●	●●	●●	●●	●●	●●			
M 26							●			●			●●	●●	●●	●●	●●	●●	●●	●●	●●			
M 27							●			●●			●●	●●	●●	●●	●●	●●	●●	●●	●●			
M 28							●			●●			●●	●●	●●	●●	●●	●●	●●	●●	●●			
M 30							●			●			●●	●●	●●	●●	●●	●●	●●	●●	●●	●●		
M 32							●			●			●●	●●	●●	●●	●●	●●	●●	●●	●●	●●		
M 33							●			●			●●	●●	●●	●●	●●	●●	●●	●●	●●	●●		
M 34							●			●			●●	●●	●●	●●	●●	●●	●●	●●	●●	●●		
M 35							●			●			●●	●●	●●	●●	●●	●●	●●	●●	●●	●●		
M 36							●			●			●●	●●	●●	●●	●●	●●	●●	●●	●●	●●		
M 38							●			●			●●	●●	●●	●●	●●	●●	●●	●●	●●	●●		
M 39							●			●			●●	●●	●●	●●	●●	●●	●●	●●	●●	●●		
M 40							●			●			●●	●●	●●	●●	●●	●●	●●	●●	●●	●●		
M 42							●			●			●●	●●	●●	●●	●●	●●	●●	●●	●●	●●		
M 45							●			●			●●	●●	●●	●●	●●	●●	●●	●●	●●	●●		
M 48							●			●			●●	●●	●●	●●	●●	●●	●●	●●	●●	●●		
M 50							●			●			●●	●●	●●	●●	●●	●●	●●	●●	●●	●●		
M 52							●			●			●●	●●	●●	●●	●●	●●	●●	●●	●●	●●		
M 55							●			●			●●	●●	●●	●●	●●	●●	●●	●●	●●	●●		
M 56							●			●			●●	●●	●●	●●	●●	●●	●●	●●	●●	●●		
M 58							●			●			●●	●●	●●	●●	●●	●●	●●	●●	●●	●●		
M 60							●			●			●●	●●	●●	●●	●●	●●	●●	●●	●●	●●		
M 62							●			●			●●	●●	●●	●●	●●	●●	●●	●●	●●	●●		
M 64							●			●			●●	●●	●●	●●	●●	●●	●●	●●	●●	●●		
M 65							●			●			●●	●●	●●	●●	●●	●●	●●	●●	●●	●●		
M 68							●			●			●●	●●	●●	●●	●●	●●	●●	●●	●●	●●		
M 70							●			●			●●	●●	●●	●●	●●	●●	●●	●●	●●	●●		
M 75							●			●			●●	●●	●●	●●	●●	●●	●●	●●	●●	●●		
M 80							●			●			●●	●●	●●	●●	●●	●●	●●	●●	●●	●●		
M 85							●			●			●●	●●	●●	●●	●●	●●	●●	●●	●●	●●		
M 90							●			●			●●	●●	●●	●●	●●	●●	●●	●●	●●	●●		
M 95							●			●			●●	●●	●●	●●	●●	●●	●●	●●	●●	●●		
M 100							●			●			●●	●●	●●	●●	●●	●●	●●	●●	●●	●●		

ユニファイねじ用限界ゲージ在庫表
Stock List of Limit Gauges for Unified Threads

サイズ size	プラグ Plug		リング Ring	
	GPIP2B	GPWP2B	GRIR2A	GRWR2A
No.2 -64UNF	●	●	●	●
No.2 -56UNC	●	●	●	●
No.3 -56UNF	●	●	●	●
No.3 -48UNC	●	●	●	●
No.4 -48UNF	●	●	●	●
No.4 -40UNC	●	●	●	●
No.5 -44UNF	●	●	●	●
No.5 -40UNC	●	●	●	●
No.6 -40UNF	●	●	●	●
No.6 -32UNC	●	●	●	●
No.8 -36UNF	●	●	●	●
No.8 -32UNC	●	●	●	●
No.10 -32UNF	●	●	●	●
No.10 -24UNC	●	●	●	●
1/4 -28UNF	●	●	●	●
1/4 -20UNC	●	●	●	●
5/16 -24UNF	●	●	●	●
5/16 -18UNC	●	●	●	●
3/8 -24UNF	●	●	●	●
3/8 -16UNC	●	●	●	●
7/16 -20UNF	●	●	●	●
7/16 -14UNC	●	●	●	●
1/2 -20UNF	●	●	●	●
1/2 -13UNC	●	●	●	●
9/16 -18UNF	●	●	●	●
9/16 -12UNC	●	●	●	●
5/8 -18UNF	●	●	●	●
5/8 -11UNC	●	●	●	●
3/4 -16UNF	●	●	●	●
3/4 -10UNC	●	●	●	●
7/8 -14UNF	●	●	●	●
7/8 -9 UNC	●	●	●	●
1 -12UNF	●	●	●	●
1 -8 UNC	●	●	●	●

管用テーパねじゲージ在庫表
Stock List of Gauges for Taper Pipe Threads

R サイズ size	プラグ Plug	リング Ring
R 1/16 -28	●	●
R 1/8 -28	●	●
R 1/4 -19	●	●
R 3/8 -19	●	●
R 1/2 -14	●	●
R 3/4 -14	●	●
R 1 -11	●	●
R 1 1/4 -11	●	●
R 1 1/2 -11	●	●
R 2 -11	●	●

管用平行ねじゲージ在庫表
Stock List of Limit Gauges for Parallel Pipe Threads

G サイズ size	プラグ Plug	リング Ring	
	GNPN	GRNR-A	GRNR-B
G 1/16 -28	●		●
G 1/8 -28	●		●
G 1/4 -19	●		●
G 3/8 -19	●		●
G 1/2 -14	●		●
G 5/8 -14	●		●
G 3/4 -14	●		●
G 7/8 -14	●		●
G 1 -11	●		●
G 1 1/8 -11	●		●
G 1 1/4 -11	●		●
G 1 1/2 -11	●		●
G 1 3/4 -11	●		●
G 2 -11	●		●

PF-A級 サイズ size	プラグ Plug		リング Ring	
	GPIP-A	GPWP-A	GRIR-A	GRWR-A
PF 1/8 -28	●	●	●	●
PF 1/4 -19	●	●	●	●
PF 3/8 -19	●	●	●	●
PF 1/2 -14	●	●	●	●
PF 3/4 -14	●	●	●	●
PF 1 -11	●	●	●	●

PF-B級 サイズ size	プラグ Plug		リング Ring	
	GPIP-B	GPWP-B	GRIR-B	GRWR-B
PF 1/8 -28	●	●	●	●
PF 1/4 -19	●	●	●	●
PF 3/8 -19	●	●	●	●
PF 1/2 -14	●	●	●	●
PF 5/8 -14	●	●	●	●
PF 3/4 -14	●	●	●	●
PF 7/8 -14	●	●	●	●
PF 1 -11	●	●	●	●
PF 1 1/8 -11	●	●	●	●
PF 1 1/4 -11	●	●	●	●
PF 1 1/2 -11	●	●	●	●
PF 1 3/4 -11	●	●	●	●
PF 2 -11	●	●	●	●

PT サイズ size	プラグ Plug	リング Ring	セット Set
PT 1/16 -28	●	●	●
PT 1/8 -28	●	●	●
PT 1/4 -19	●	●	●
PT 3/8 -19	●	●	●
PT 1/2 -14	●	●	●
PT 3/4 -14	●	●	●
PT 1 -11	●	●	●
PT 1 1/4 -11	●	●	●
PT 1 1/2 -11	●	●	●
PT 2 -11	●	●	●

ANSI管用テーパねじゲージ在庫表
Stock List of Gauges for ANSI Taper Pipe Threads

NPT サイズ size	プラグ Plug	リング Ring	セット Set
NPT 1/8 -27	●	●	●
NPT 1/4 -18	●	●	●
NPT 3/8 -18	●	●	●
NPT 1/2 -14	●	●	●
NPT 3/4 -14	●	●	●
NPT 1 -11 1/2	●	●	●
NPT 1 1/4 -11 1/2	●	●	●
NPT 1 1/2 -11 1/2	●	●	●
NPT 2 -11 1/2	●	●	●

NPTF サイズ size	プラグ Plug	リング Ring	セット Set
NPTF 1/8 -27	●	●	●
NPTF 1/4 -18	●	●	●
NPTF 3/8 -18	●	●	●
NPTF 1/2 -14	●	●	●
NPTF 3/4 -14	●	●	●
NPTF 1 -11 1/2			
NPTF 1 1/4 -11 1/2			
NPTF 1 1/2 -11 1/2			
NPTF 2 -11 1/2			

限界プラグゲージ在庫表
Stock List of Limit Plug Gauges

検査用の在庫サイズはφ1~φ35
The stock items for inspection use are for diameter φ1~φ35

サイズ size	H7 工作用・検査用 Production・inspection
1.0	●
2.0	●
3.0	●
4.0	●
5.0	●
6.0	●
7.0	●
8.0	●
9.0	●
10.0	●

サイズ size	H7 工作用・検査用 Production・inspection
11.0	●
12.0	●
13.0	●
14.0	●
15.0	●
16.0	●
17.0	●
18.0	●
19.0	●
20.0	●

サイズ size	H7 工作用・検査用 Production・inspection
21.0	●
22.0	●
23.0	●
24.0	●
25.0	●
26.0	●
27.0	●
28.0	●
29.0	●
30.0	●

サイズ size	H7 工作用・検査用 Production・inspection
31.0	●
32.0	●
33.0	●
34.0	●
35.0	●
36.0	●
37.0	●
38.0	●
39.0	●
40.0	●

サイズ size	H7 工作用 Production
41.0	●
42.0	●
43.0	●
44.0	●
45.0	●
46.0	●
47.0	●
48.0	●
49.0	●
50.0	●

マスターリングゲージ在庫表
Stock List of Master Ring Gauges

サイズ size	Tolerance ±0.001
2.0	●
3.0	●
4.0	●
5.0	●
6.0	●
7.0	●
8.0	●
9.0	●
10.0	●
11.0	●
12.0	●
13.0	●
14.0	●
15.0	●
16.0	●
17.0	●
18.0	●
19.0	●
20.0	●

サイズ size	Tolerance ±0.00125
21.0	●
22.0	●
23.0	●
24.0	●
25.0	●
26.0	●
27.0	●
28.0	●
29.0	●
30.0	●
31.0	●
32.0	●
33.0	●
34.0	●
35.0	●
36.0	●
37.0	●
38.0	●
39.0	●

サイズ size	Tolerance ±0.00125
40.0	●
41.0	●
42.0	●
43.0	●
44.0	●
45.0	●
46.0	●
47.0	●
48.0	●
49.0	●
50.0	●
52.0	●
54.0	●
55.0	●
56.0	●
58.0	●
60.0	●
62.0	●
64.0	●

サイズ size	Tolerance ±0.00125
65.0	●
66.0	●
68.0	●
70.0	●
72.0	●
74.0	●
75.0	●
76.0	●
78.0	●
80.0	●

サイズ size	Tolerance ±0.002
82.0	●
84.0	●
85.0	●
86.0	●
88.0	●
90.0	●
92.0	●
94.0	●
95.0	●
96.0	●
98.0	●
100.0	●

その他のゲージ在庫表
Stock List of Other Gauges

- ・メートルねじ限界ゲージ 従来JIS 1級・左ねじ(検査用)
- ・標準ねじゲージ メートル用・管用PF
- ・下孔栓ゲージ WM2
- ・モールステーパゲージ
- ・Limit gauges for Metric threads, Conventional JIS class 1 threads/Left hand threads (for Inspection)
- ・Standard Thread Gauges. PF for metric threads/pipe threads
- ・Limit Plug Gauge WM class2
- ・Morse Taper Gauge

主なねじ規格一覧表

List of Major Thread Specifications

■ 平行ねじ規格一覧

Parallel Thread Specifications

ねじの種類 Type of Thread	記号 Marks	規格 Specification	ねじ山角度 Pitch Angle	ねじの等級 Thread Class	用途 Use	ゲージ規格 Standard for Screw thread gauge
メートルねじ(ISO等級) Metric (ISO Class)	M	JIS B 0205 JIS B 0209	60°	4H,5H,6H,7H 4h,6h,6g,8g	一般機械、自動車産業 General Machinery and automobile industry	JIS B 0251
メートルねじ(1~3級) Metric (Class1~3)		JIS B 0207(旧) JIS B 0211(旧)		1,2,3級 Class1,2,3		—
ユニファイねじ(並目) Unified (Coarse)	UNC	JIS B 0206 JIS B 0210		3B,2B,1B 3A,2A,1A		JIS B 0255
ユニファイねじ(細目) Unified (Fine)	UNF	JIS B 0208 JIS B 0212				
管用平行ねじ Parallel Pipe	G	JIS B 0202	55°	めねじ1種類・おねじA,B級 Female 1 type, Male Class A, B	管、液体機器 Pipe, Liquid containers	JIS B 0254
	PF	JIS B 0202付属書 Appendix		A,B級 Class A, B		JIS B 0254付属書 Appendix
厚鋼電線管ねじ Thick Wall Conduit Pipe	CTG	JIS C 8305付属書 Appendix	55°	(1種類) (1 type)	電線管 Conduit pipe	—
薄鋼電線管ねじ Thin Wall Conduit Pipe	CTC		80°			
メートル台形ねじ Metric(30°) Trapezoidale	Tr	JIS B 0216 JIS B 0217 JIS B 0218	30°	7H,8H 7e,8c	推力伝達用、親ねじ Rotation conduction Mother screw	JMAS 4007
30度台形ねじ Metric(30°) Trapezoidale	TM	JIS B 0216付属書	30°		推力伝達用、親ねじ Rotation conduction Mother screw	—
29度台形ねじ Metric(29°) Trapezoidale	TW	JIS B 0222(旧)	29°			
自転車ねじ(一般用) Bicycle(general purpose)	BC	JIS B 0225	60°	(1種類) (1 type)	自転車、リヤカー Bicycle, rear-car	JMAS 4002
自転車ねじ(スポーク用) Bicycle(for spokes)						
ミシン用ねじ Sewing Machine	SM	JIS B 0226		1,2,3級 Class 1,2,3	一般ミシン Sewing machines	—
自動車用タイヤバルブステムねじ Automobile Tire Valve Stem	TV	JIS D 4208			自動車タイヤバルブ Automobile tire valve	—
自転車用タイヤバルブねじ Bicycle Tire Valve	CTV	JIS D 9422		自転車タイヤバルブ Bicycle tire valve	JMAS 4002	
写真レンズ用ねじ Camera Lens	M	JIS B 7111		(1種類) (1 type)	写真機、付属品 Camera and accessories	—
給水せん取付ねじ Tap ater Fixture Valve	—	JIS B 2061	55°		給水栓 Water tap	—
鋼製ドラム用口金ねじ Steel Drum Lid	—	JIS Z 1604			鋼製ドラム口金 Drum Lids	
ユニファイねじ(米) Unified Thread	UNC	ANSI B1.1	60°	3B,2B,1B 3A,2A,1A	一般機械、自動車産業 General Machinery and automobile industry	ANSI B 1.2
	UNF					ANSI/ASME B 1.2
	UNEF					
	4UN,6UN					
	8UN,12UN					
	16UN,20UN					
28UN,32UN						
航空宇宙用メートルねじ Metric Thread Aerospace	MJ	ISO 5855		4H5H,4H6H,4h6h		ISO5855-1~3
航空宇宙用インチねじ Inch Thread for Aerospace	UNJC	MIL-S-8879 (ISO 3161)	60°	3B,3A	航空宇宙用 Aerospace Use	NBS HAND BOOK H28
	UNJF					
	UNJEF					
	8UNJ					
	12UNJ					
	16UNJ					
管用平行ねじ(米) Parallel Pipe(USA)	NPSC	ANSI/ASME B 1.20.1	60°	(1種類) (1 type)	管継手 Pipe junction	ANSI/ASME B 1.20.1
	NPSF	ANSI B 1.20.3			ドライシール管継手 Dry seal pipe junction	ANSI B1.20.5
	NPSH	ANSI/ASME B 1.20.7			ホース継手 Hose junction	ANSI/ASME B 1.20.1
	NPSL	ANSI/ASME B 1.20.1			ロックナット Lock nut	
	NPSM	ANSI/ASME B 1.20.1			機械継手 Machine fitting	
アクメねじ(米) ACME(USA)	ACME	ANSI B1.5	29°	5G,4G,3G,2G 6C,5C,4C,3C,2C	推力伝達用、親ねじ Rotation conduction, mother screw	ANSI B 1.5
スタップアクメねじ STUB ACME(USA)	STUB,ACME	ANSI B1.8		(1種類) (1 type)		ANSI B 1.8
バットレスねじ(米) Buttress Thread(USA)	BUTT	ANSI B1.9	7°×45°	class3 class2	推力伝達用 Rotation conduction	ANSI B 1.9
ウィットねじ(並目)(英) Whitworth(Coarse)(UK)	BSW	BS 84	55°	medium normal close	一般機械 General Machinery	BS 84
ウィットねじ(細目)(英) Whitworth(Fine)(UK)						
特殊ねじ(英) Special Thread(UK)	BA	BS 93	47.5°	(1種類)/close normal (1 type)/close, normal	精密機械 Precision Machinery	BS 93

■テーパねじ規格一覧
Taper Thread Specifications

ねじの種類 Type of Thread	記号 Marks	規格 Specification	ねじ山角度 Pitch Angle	テーパ Taper	ゲージ規格 Standard for Screw thread gauge
管用テーパおねじ Male Taper Pipe (ISO)	R	JIS B 0203	55°	1/16	JIS B 0253
管用テーパめねじ Female Taper Pipe (ISO)	Rc				
管用平行めねじ Female Parallel Pipe (ISO)	Rp				
管用テーパねじ Taper Pipe	PT				
管用平行めねじ Female Parallel Pipe	PS				
継目なし鋼製高圧ガス容器弁取付部ねじ Screw thread for Seamless Steel Gas Cylinders	—	JIS B 8241	55°	3/26	—
液化石油ガス容器用弁ねじ Screw thread for Valves for Liquefide Petroleum Gas Cylinders	—	JIS B 8245			JIS B 8245~6 解説 Explanation
高圧ガス容器用弁ねじ Screw thread for Valves for High Pressure Gas Cylinders	—	JIS B 8246			
管用テーパねじ(英) Taper Pipe (UK)	BSPT	BS 21	55°	1/16	BS 21
管用テーパねじ(米) Taper Pipe (USA)	NPT	ANSI/ASME B 1.20.1	60°		ANSI/ASME B1.20.1
管用テーパねじ(米) Taper Pipe (USA) (ドライシールねじ) (Dry Seal Taper Pipe)	NPTF	ANSI/ASME B 1.20.3			ANSI B1.20.5
ANPT管用ねじ(米) Taper Pipe (USA)	ANPT	MIL-P-7105 B			MIL-P-7105 B

メートルねじの従来JIS等級とISO導入によるJIS等級の比較

Comparison between Conventional JIS Class and ISO-based JIS Class for Metric Threads

■メートル並目ねじ
Metric Coarse Threads

おねじ・めねじの別 Male/Female	ISO導入JIS等級 ISO-based JIS Class	呼びの範囲 Nominal Range	従来JIS等級 Conventional JIS	呼びの範囲 Nominal Range
おねじ Male	4h	M1~M68	1級 Class 1	M1~M68
	6h	M1~M1.4	2級 Class 2	M1~M68
	6g	M1.6~M68		
	8g	M5×0.8~M68	3級 Class 3	M5×0.8~M68
めねじ Female	4H	M1~M1.4	1級 Class 1	M1~M68
	5H	M1.6~M68		
	5H	M1~M1.4	2級 Class 2	M1~M68
	6H	M1.6~M68		
	7H	M3×0.5~M68	3級 Class 3	M3×0.5~M68

■メートル細目ねじ
Metric Fine Threads

おねじ・めねじの別 Male/Female	ISO導入JIS等級 ISO-based JIS Class	呼びの範囲 Nominal Range	従来JIS等級 Conventional JIS	呼びの範囲 Nominal Range
おねじ Male	4h	M1×0.2~M150×2	1級 Class 1	M1×0.2~M150×2
	6h	M1×0.2~M1.4×0.2	2級 Class 2	M1×0.2~M150×2
	6g	M1.6×0.2~M150×2		
	8g	M8×1.0~M150×2	3級 Class 3	M8×1.0~M150×2
めねじ Female	4H	M1×0.2~M1.8×0.2	1級 Class 1	M1×0.2~M150×2
	5H	M2×0.25~M150×2		
	6H	M2.5×0.35~M150×2	2級 Class 2	M2.5×0.35~M150×2
	7H	M4×0.5~M150×2	3級 Class 3	M4×0.5~M150×2

従来JISゲージとISO導入JISゲージの相違点

The Difference between Conventional JIS Gauges and ISO-based JIS Gauges

- | | |
|--|--|
| <p>①従来JISゲージには検査用・工作用の区別がりましたがISOゲージ方式では検査用・工作用の区別はありません。</p> <p>②おねじ外径用としてISOゲージ方式ではリングゲージが加えられました。</p> <p>③摩耗点検プラグは、従来JISゲージでは通りねじリング用のみ限定されておりましたが、ISOゲージ方式では止りねじリングゲージにも設けられました。</p> | <p>①Differ from ISO gauging system, there is a distinction between gauges for inspection and production use in conventional JIS.</p> <p>②ISO gauging system adds the ring gauges for measuring outside diameter of male threads.</p> <p>③In conventional JIS, wear inspection plug is only for GO thread ring gauge, while in ISO system it is used also for NOT GO thread ring gauge.</p> |
|--|--|

ねじリングゲージの点検方法

Inspection Method of Thread Ring Gauges

従来JISゲージ方式ではねじリングゲージにはめ合い点検ゲージが無理なくしっかりとめ合わされることで合格と判定しましたが、ISOゲージ方式では通りねじリングゲージ(GR)に通り点検プラグ(GRGF)が通り抜け、止り点検プラグ(GRNF)がどちらからも1回転を超えてねじ込まれないことで合格と判定します。

また、止りねじリングゲージ(NR)においても点検プラグ(NRGF)(NRNF)が同様に用いられます。

In conventional JIS, acceptance is given when the inspection plug fitted perfectly without difficulty into the thread ring gauge.

While in ISO gauging system, acceptance is given when GO inspection plug (GRGF) can pass through GO thread ring gauge (GR) and NOT GO inspection plug (GRNF) can not be screwed more than one turn from either sides of gauges (NR).

限界ねじゲージでの合否の判定方法

Judgment Methods for Limit Thread Gauges

通り側ゲージは無理なく通り抜け、止り側ゲージにおいては従来JISゲージ方式ではどちらからも2回転以上ねじ込まれないこと、ISO導入JISゲージ方式ではどちらからも2回転を超えてねじ込まれない場合そのねじは合格と判定します。

The threads are judged pass when GO gauge can go through smoothly and NOT GO gauge can not be screwed two turns or more in conventional JIS and more than two turns in ISO-based JIS, from either sides of the threads.

摩耗点検プラグでの合否の判定方法

Judgement Methods for Wear Inspection Plug

この点検ゲージはねじゲージの有効径が規定された摩耗限界を超えていないかどうかを確認するために使用します。判定の基準はISO導入JISと従来JISによって異なります。

Inspection plugs are used to check whether the effective diameters of thread gauges are within the specified wear limit or not.

The judgement standard of the plugs for ISO-based JIS and conventional JIS are different.

・ISO導入JIS

通り側摩耗点検ゲージを使用中の通り側ねじリングゲージに無理なくねじ込んだ時、どちら側からも1回転を超えてねじ込まれてはならない。

止り側摩耗点検ゲージは止り側ねじリングゲージに無理なくねじ込んだ時、どちら側からも1回転を超えてねじ込まれてはならない。

・ISO-based JIS

When GO side of wear inspection gauges can screw smoothly into GO side of thread ring gauge used, it should not more than one turn from either sides of the gauges.

When NOT GO side of wear inspection gauges can screw smoothly into NOT GO side of thread ring gauges, it should not more than one turn from either sides of the gauges.

・従来JIS

通り側摩耗点検ゲージを使用中の通り側ねじリングゲージに無理なくねじ込んだ時、通り抜けないことで、摩耗限度内であると判断する。

止り側摩耗点検ゲージは規格にはないが通り側摩耗点検ゲージを参考に設計されたもので、止り側摩耗点検ゲージを使用中の止り側ねじリングゲージに無理なくねじ込んだ時、通り抜けないことで、摩耗限度内であると判断する。

・Conventional JIS

When GO side of wear inspection plug can screw smoothly into GO side of thread ring gauge, it is considered within wear-limit when the plug does not pass through.

When NOT GO side of wear inspection plug can screw smoothly into NOT GO side of thread ring gauge, it is considered within wear-limit when the plug does not pass through.

NOT GO side of wear inspection plugs are designed by considering GO side of wear inspection gauge which is not specified in the standard.







ねじ用限界ゲージの種類、等級、記号および公差相互の関係図

Chart of Mutual Relationships of Type, Class, Marks and Tolerance of Limit Gauges for Screw Threads (Conventional JIS Threads and ISO-based JIS Threads)

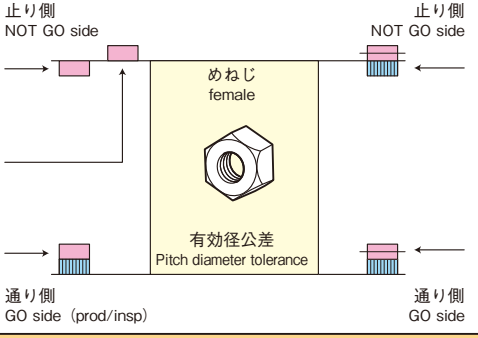
■ 限界ねじゲージ

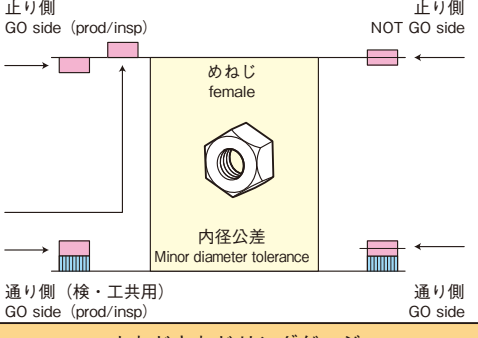
Thread Limit gauges

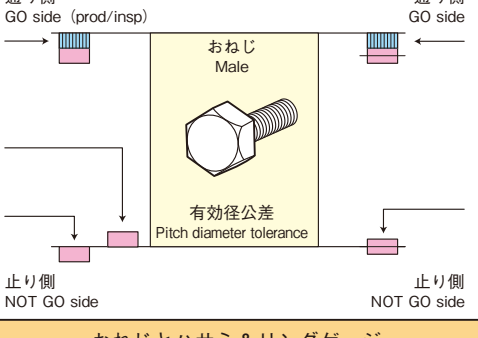
...ゲージ公差 ...Gauge tolerance
 ...摩耗しろ ...wear allowance

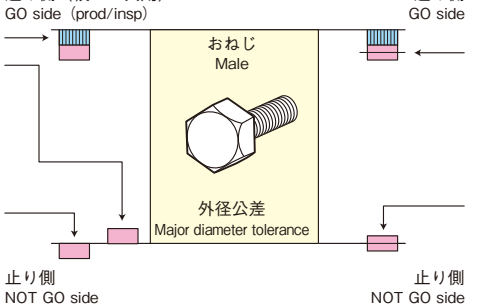
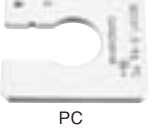
従来JISゲージ (メートル・ユニファイねじ用) Conventional JIS Gauges (Metric, Unified)			製品公差とゲージとの関係図 Relationship between product tolerances & gauges			ISO導入によるJISゲージ (メートルねじ用) ISO-based JIS Gauges for Metric Thread			
限界ねじプラグゲージ Thread Limit Plug gauge	等級 Class	記号 Mark	めねじとねじプラグゲージ Female Thread & Thread Plug Gauges			記号 Mark	等級 Class	限界ねじプラグゲージ Thread Limit Plug gauge	
通り GO 止り NOT GO  GP	1	WP (工作用) production	 めねじ female 有効径公差 Pitch diameter tolerance	NP	4H	通り GO	止り NOT GO		
	2	IP (検査用) inspection				5H	通り GO	止り NOT GO	
	3	GP (検工共用)				6H	GP	NP	
限界プラグゲージ Limit Plug gauge	等級 Class	記号 Mark	めねじとプラグゲージ Female Thread & Thread Plug Gauges			記号 Mark	等級 Class	プレーンプラグゲージ Plain Plug gauge	
通り GO 止り NOT GO  WMまたはIM WM or IM	1	WM (工作用) production	 めねじ female 内径公差 Minor diameter tolerance	PP	4H	通り GO	止り NOT GO		
	2	IM (検査用) inspection				5H	通り GO	止り NOT GO	
	3					6H	PP		
限界ねじリングゲージ Thread Limit Ring gauge	等級 Class	記号 Mark	おねじとねじリングゲージ Male Thread & Thread Ring Gauges			記号 Mark	等級 Class	限界ねじリングゲージ Thread Limit Ring gauge	
通り GO 止り NOT GO  GR	1	GR (検工共用)	 おねじ Male 有効径公差 Pitch diameter tolerance	GR	4h	通り GO	止り NOT GO		
	2	WR (工作用) production				6h	通り GO	止り NOT GO	
	3	IR (検査用) inspection				6g	GR	NR	
限界挟みゲージ Limit Caliper Gauge	等級 Class	記号 Mark	おねじとハサミ & リングゲージ Male Thread & Caliper & Ring Gauge			記号 Mark	等級 Class	プレーン挟みゲージ & プレーンリングゲージ Limit Caliper Gauge & Ring Gauge	
 WSまたはIS WS or IS	1	WS (工作用) production	 おねじ Male 外径公差 Major diameter tolerance	PC	4h	 PC			
	2	IS (検査用) inspection				6h	6g	通り GO	止り NOT GO
	3							8g	PR

ねじ用限界ゲージの種類、等級、記号および公差相互の関係図

Chart of Mutual Relationships of Type, Class, Marks and Tolerance of Limit Gauges for Screw Threads(Conventional JIS Threads and ISO-based JIS Threads)

■限界ねじ用点検ゲージ

Inspection Gauges for Thread Limit gauges

はめ合い点検ねじプラグゲージ Thread Plug Gauge for Checking Fit		等級 Class	記号 Mark	点検されるねじリングゲージ Thread Ring Gauge to be checked		記号 Mark	等級 Class	点検プラグ Check plug for thread ring gauge	
通り GO	止り NOT GO	1	GF	従来JIS GR用 Conventional JIS for GR	通り側 GO side	ISO導入 GR用 ISO-based for GR	4h	通り GO	止り NOT GO
GF	WFまたはIF WF or IF		GRGF		GRNF				
GF	WFまたはIF WF or IF	2	GW	WR用 for WR	通り側 GO side	NR用 for NR	6h	GRGF	GRNF
			WF					NRGF	GW
GW	WFまたはIF WF or IF	3	IF	IR用 for IR	止り側 NOT GO side	NR用 for NR	8g	NRGF	NRNF
			IF	IR用 for IR	止り側 NOT GO side			NW	NW

各種ゲージの注文仕様書

Ordering Form for the Gauges

仕様項目 Specifications		例1)限界ねじゲージ Example 1) Thread Limit Gauge	例2)限界ゲージ Example 2) Limit Gauge
1	ゲージの種類 Type of gauge	限界ねじリングゲージ Thread Limit Ring Gauge	限界プラグゲージ Limit Plug Gauge
2	呼び寸法、ピッチ・等級 Nominal size, pitch and class	M10×1.5 6g	φ20 H7
3	セットまたは片側のどちらか Single or pair	GR, NR	Set
4	左ねじおよび多条ねじ等の指示 Thread Type	左 Left-hand	—
5	適用規格または製品公差 Applicable specifications and product tolerances	JIS	工作用 Production
6	規格外の場合は、その内容 details of non-standard specifications	ねじの許容限界寸法および公差やねじ部長さ Limit size of thread tolerance	—
7	特殊仕様の場合は、その内容 Details of any special specifications	メッキ代 -0.03 Plating -0.03	首下50 Under neck length50,
8	材質が特殊の場合 For special materials	—	超硬 Carbide

仕様が特殊の場合は図面の添付をお願いいたします。
Please attach the drawing for special specifications.

M10 × 1.5 GRNR -6g LH -0.03

① ② ③ ④ ⑤ ⑥

①	M10	呼び寸法	Nominal Diameter
②	1.5	ピッチ	pitch
③	GRNR	ゲージの種類	Type of gauges
④	6g	等級	Class
⑤	LH	左ねじ	Left hand
⑥	-0.03	メッキ代	Plating

新JIS (ISO) におけるゲージシステム

Gauging System in new JIS (ISO)

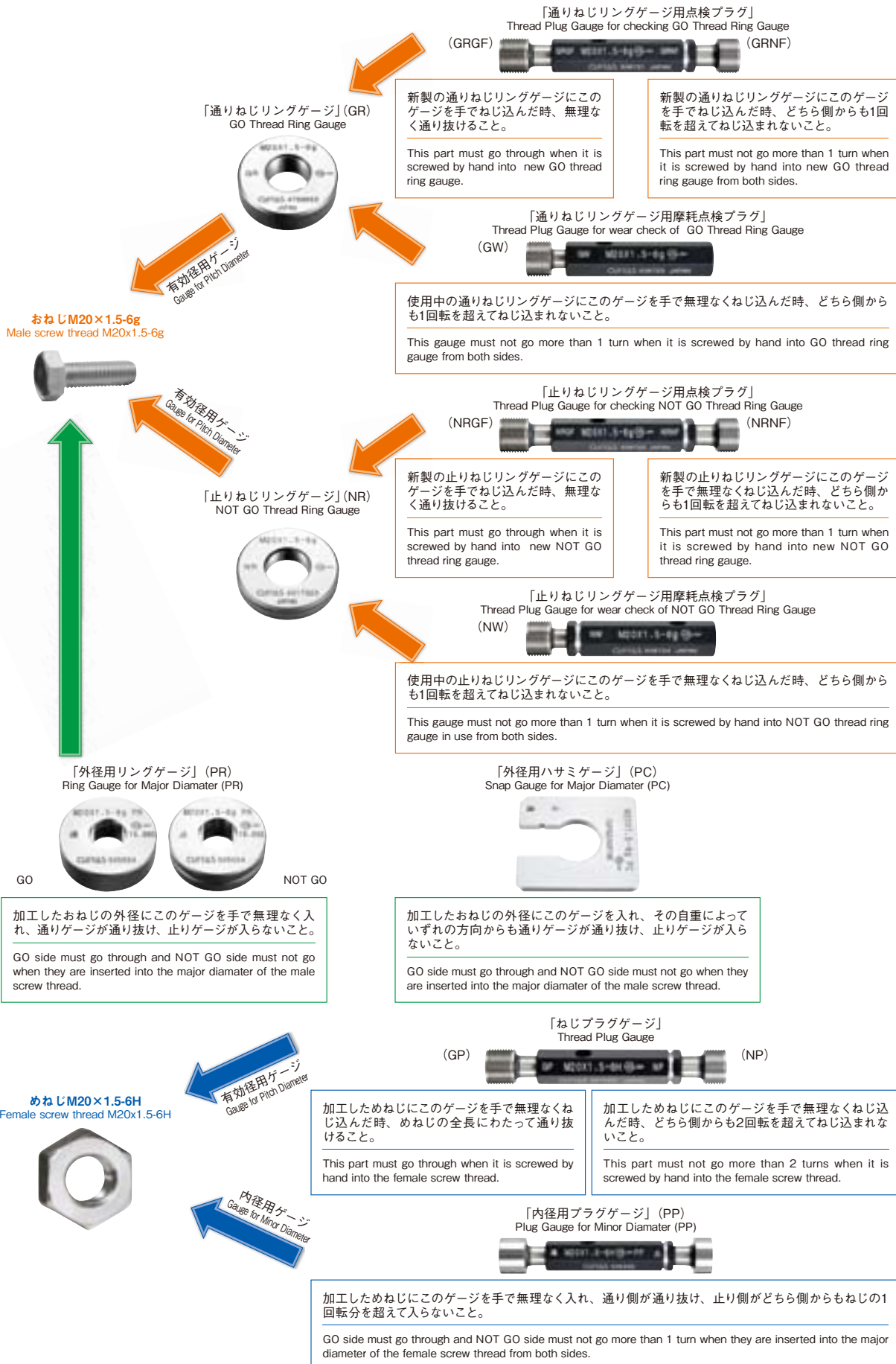

ユニファイねじの呼びと山数一覧表

注) 表に該当しないユニファイねじの山数は UNS となります

Note) Unified screw thread which do not fall under the above category are classified into UNS.

Table of nominal designation and threads per inch of unified screw thread

呼び Nominal Size		外径 Basic Major Diameter		(山数) Threads/inch													
Primary	Secondary	インチ inch	ミリ mm	Series With Graded Pitches			Series With Constant Pitches										
				Coarse UNC	Fine UNF	Extra Fine UNEF	(6.350) 4-UN	(4.233) 6-UN	(3.175) 8-UN	(2.116) 12-UN	(1.587) 16-UN	(1.270) 20-UN	(0.907) 28-UN	(0.793) 32-UN			
No.0	...	0.0600	1.524	...	80
...	No.1	0.0730	1.854	64	72
No.2	...	0.0860	2.184	56	64
...	No.3	0.0990	2.515	48	56
No.4	...	0.1120	2.845	40	48
No.5	...	0.1250	3.175	40	44
No.6	...	0.1380	3.505	32	40	UNC
No.8	...	0.1640	4.166	32	36	UNC
No.10	...	0.1900	4.826	24	32	UNF
...	No.12	0.2160	5.486	24	28	32	UNF	UNEF
1/4	...	0.2500	6.350	20	28	32	UNC	UNF	UNEF	28	32	UNEF
5/16	...	0.3125	7.938	18	24	32	20	28	28	28	28	UNEF
3/8	...	0.3750	9.525	16	24	32	UNC	20	28	28	28	UNEF
7/16	...	0.4375	11.113	14	20	28	16	UNF	UNEF	28	32	UNEF
1/2	...	0.5000	12.700	13	20	28	16	UNF	UNEF	28	32	UNEF
9/16	...	0.5625	14.288	12	18	24	UNC	16	20	28	28	28	32
5/8	...	0.6250	15.875	11	18	24	12	16	20	28	28	28	32
...	11/16	0.6875	17.463	24	12	16	20	28	28	28	32
3/4	...	0.7500	19.050	10	16	20	12	UNF	UNEF	28	32	28	32
...	13/16	0.8125	20.638	20	12	16	UNEF	28	32	28	32
7/8	...	0.8750	22.225	9	14	20	12	16	UNEF	28	32	28	32
...	15/16	0.9375	23.813	20	12	16	UNEF	28	32	28	32
1	...	1.0000	25.400	8	12	20	UNC	UNF	16	UNEF	28	32	28	32	32
...	1 1/16	1.0625	26.988	18	8	12	16	20	28	28	28	28	...
1 1/8	...	1.1250	28.575	7	12	18	8	UNF	16	20	28	28	28	28	...
...	1 3/16	1.1875	30.163	18	8	12	16	20	28	28	28	28	...
1 1/4	...	1.2500	31.750	7	12	18	8	UNF	16	20	28	28	28	28	...
...	1 5/16	1.3125	33.338	18	8	12	16	20	28	28	28	28	...
1 3/8	...	1.3750	34.925	6	12	18	...	UNC	8	UNF	16	20	28	28	28	28	...
...	1 7/16	1.4375	36.513	18	...	6	8	12	16	20	28	28	28	28	...
1 1/2	...	1.5000	38.100	6	12	18	...	UNC	8	UNF	16	20	28	28	28	28	...
...	1 9/16	1.5625	39.688	18	...	6	8	12	16	20
1 5/8	...	1.6250	41.275	18	...	6	8	12	16	20
...	1 11/16	1.6875	42.863	18	...	6	8	12	16	20
1 3/4	...	1.7500	44.450	5	6	8	12	16	20
...	1 13/16	1.8125	46.038	6	8	12	16	20
1 7/8	...	1.8750	47.625	6	8	12	16	20
...	1 15/16	1.9375	49.213	6	8	12	16	20
2	...	2.0000	50.800	4 1/2	6	8	12	16	20
...	2 1/8	2.1250	53.975	6	8	12	16	20
2 1/4	...	2.2500	57.150	4 1/2	6	8	12	16	20
...	2 3/8	2.3750	60.325	6	8	12	16	20
2 1/2	...	2.5000	63.500	4	UNC	6	8	12	16	20
...	2 5/8	2.6250	66.675	4	6	8	12	16	20
2 3/4	...	2.7500	69.850	4	UNC	6	8	12	16	20
...	2 7/8	2.8750	73.025	4	6	8	12	16	20
3	...	3.0000	76.200	4	UNC	6	8	12	16	20
...	3 1/8	3.1250	79.375	4	6	8	12	16
3 1/4	...	3.2500	82.550	4	UNC	6	8	12	16
...	3 3/8	3.3750	85.725	4	6	8	12	16
3 1/2	...	3.5000	88.900	4	UNC	6	8	12	16
...	3 5/8	3.6250	92.075	4	6	8	12	16
3 3/4	...	3.7500	95.250	4	UNC	6	8	12	16
...	3 7/8	3.8750	98.425	4	6	8	12	16
4	...	4.0000	101.600	4	UNC	6	8	12	16
...	4 1/8	4.1250	104.775	4	6	8	12	16
4 1/4	...	4.2500	107.950	4	6	8	12	16
...	4 3/8	4.3750	111.125	4	6	8	12	16
4 1/2	...	4.5000	114.300	4	6	8	12	16
...	4 5/8	4.6250	117.475	4	6	8	12	16
4 3/4	...	4.7500	120.650	4	6	8	12	16
...	4 7/8	4.8750	123.825	4	6	8	12	16
5	...	5.0000	127.000	4	6	8	12	16
...	5 1/8	5.1250	130.175	4	6	8	12	16
5 1/4	...	5.2500	133.350	4	6	8	12	16
...	5 3/8	5.3750	136.525	4	6	8	12	16
5 1/2	...	5.5000	139.700	4	6	8	12	16
...	5 5/8	5.6250	142.875	4	6	8	12	16
5 3/4	...	5.7500	146.050	4	6	8	12	16
...	5 7/8	5.8750	149.225	4	6	8	12	16
6	...	6.0000	152.400	4	6	8	12	16

校正点検のご案内

Guidance for Periodic Inspection

各種ゲージは計測の原器であると同時に消耗工具でもあります。よって許容差をはずれて使用された場合には大きな問題となります。

使用頻度が少ないことや測定条件(温度、測定機器)などに不足があることを理由に、定期的な点検を怠ることはないでしょうか。

弊社では皆様に代わって各種ゲージの校正点検を承っております。

詳細は弊社営業部までお問合せ下さい。

The gauges are the basic measuring tools which are subjected to wear. Therefore, any gauges which are out of specifications due to wear or other reasons may yield any potential troubles.

The users should pay attention to check periodically the gauges used even their frequency of use is low or it is difficult to provide a proper measuring condition and instruments.

OJIYA SEIKI offers a service for periodic inspection of the gauges.

Further information on the service are available through the sales office.

社内校正点検の提案

Internal Periodic Inspection

校正点検に関わる時間と費用の削減を図る上で次のご提案をいたします。

We advise the following internal inspections conducted in your office for reducing time and expenses.

・ねじプラグゲージとプレーンプラグゲージの校正
相当数のゲージを保有している場合は定期的な外部校正をされるより社内校正をお勧めいたします。
社内校正に必要な検査具は測長器、ブロックゲージ測定用三針です。検査方法は以下のようにJISに規定されています。

・ブロックゲージ JIS B 7506

・ねじ測定用三針およびねじ測定用四針 JIS B 0271

・検査方法 JIS B 0261またはJIS B 7420

なお測長器、ブロックゲージ、およびねじ測定用三針(四針)の校正は、使用頻度にもよりますが2~3年に一度で十分です。

・ねじリングゲージの校正

ねじリングゲージは、摩耗点検ねじプラグゲージを準備することにより社内校正を実施できます。

ただし、各サイズごとに摩耗点検ねじプラグゲージを準備する必要があり、費用がかかります。

1サイズあたりの保有数や、使用頻度を考慮して、社内と外部校正を使い分けすることをお勧めいたします。

社内校正に使用する摩耗点検ねじプラグゲージの校正は、上記ねじプラグゲージの校正により実施します。

Periodic Inspection for Thread Plug Gauges and Plain Plug Gauges

In case of considerable number of gauges, it is recommended to have internal periodic inspection instead of external inspection. The tools necessary for internal inspections are block gauges, length measuring tools, and three wires for screw threads measurement.

JIS specified inspection methods are as follows,

・Block Gauges
JIS B 7506

・Three and four wires for screw threads measurement
JIS B 0271

・Inspection Methods
JIS B 0261 or JIS B 7420

The inspection of block gauges, length measuring tools, three (four) wires for screw threads measurement depends on their frequency use. However, it is generally enough to inspect them once per 2 or 3 years.

Periodic Inspection for Thread Ring Gauges

Internal inspection of thread ring gauges is carried out using wear inspection thread plug gauges.

However, the costs are relative expensive since the wear inspection thread plug gauges for each size should be prepared. Therefore, it is recommended to take internal and external inspections properly by considering the number per size or the frequency use of the gauges.

The inspection of the wear inspection thread plug gauges used for internal inspection can be carried out using the above mentioned inspection method of thread plug gauges.

ゲージ類を間違いなくお使いいただくために

Safety Precautions for Using Gauges



安全上の注意

Safety Precautions

- ・ゲージを検査以外の目的で使用しないで下さい。
例えばナットやボルトの代わりにねじゲージを使用することや工具代わりにゲージを使用することは絶対にしないで下さい。破壊によるケガやゲージ精度の低下を招くとともに、場合によっては安全性を損ねる場合があります。
- ・ゲージには機能上の要求により鋭利な部分がありますので取り扱い上、十分に注意して下さい。
特にねじ用限界ゲージの場合、ねじ山および不完全ねじ山が鋭利になっていますので、包装、防錆材等をはがす時は十分注意して下さい。
- ・ハンドルの緩みや破損等により大型のゲージが落下した場合思わぬ事故につながる恐れがありますのでゲージの使用前にゲージとハンドルが緩んでいないことを必ず確認して下さい。
- ・ゲージまたは製品が運動状態にある時は、絶対にゲージによる検査をしないで下さい。
落下、破壊、飛散等により重大な事故が生じる恐れがあります。
幸い事故やケガに至らなくても、ゲージの異常、摩耗、発熱等を生じてゲージの寿命に悪影響を与えます。
- ・気化性防錆紙の取扱い後は、石鹼水または清水で手を洗って下さい。
詳細は日本防錆技術協会(TEL.03-3434-0451)にお問合せ下さい。
- ・プラスチック防錆保護材(シールピール)は、消防法による可燃性固体類に該当し、溶解時には火傷の危険があります。不用意に火中に投入しないで下さい。
また、手に付着した場合は石鹼でよく洗って下さい。
詳細は日飛興産株式会社(TEL.045-772-4012)にお問合せ下さい。

- ・Do not use the gauges for any other purpose except for inspection. Never use the thread gauges for substituting nut or bolt nor use the gauges for substitution of any tools. Such misuses of the gauges may deteriorate their precision, cause an injury by destruction or harm the safety.
- ・Please be careful when using the gauges because they contain sharp parts due to the performance requirements. Especially for limit gauges for threads, a careful attention should be paid when tearing off the corrosion proof materials or the packing, since the thread and incompleated thread are sharp.
- ・Please make sure that there is no slack between the gauge and its handle. Unexpected accident may happen when the gauge dropped by the loosen handle.
- ・Please never use gauges for inspecting a moving workpiece or gauge. Because it may cause a serious accident by dropping, destructing or scattering the workpiece or gauges. Also, the life time of the gauges will be degraded due to malformed, wear, heat generation, etc.
- ・Please wash your hand using soapy or spring water after handling a pavorized corrosion proof paper. Please contact Japan Association for Corrosion Control for further information. (Tel.81-3-3434-0451)
- ・Plastic corrosion proof material (Seal-Peel) is a specified flammable material which is dangerous when dissolved. Never throw such the material into the flames carelessly. Wash using soap carefully when the material sticks on your hand. Please contact Nippi Kousan Co.Ltd for further information. (Tel.81-45-772-4012)



ご使用前の注意

Cautions before Use

- ・ゲージを使用する前には、ゲージおよび製品をよく洗浄するか乾いたきれいな布等でよく拭きとって下さい。
- ・ゲージを使用する前には、ゲージの錆、傷、かえり等を確認し錆、傷、かえりがあった場合はアルカンサス砥石で丁寧に除去して下さい。
- ・Please wash the gauges and the workpieces or wipe off using a dry and clean cloth before use.
- ・Please check and remove them using an Arkansas whetstone if there are any dusts, burrs or wound on the gauges.



ご使用時の注意 Cautions during Use

- ・ゲージの使用に際しては、ゲージに潤滑油を十分塗布した上で使用して下さい。
製品に付着している塵埃や切粉等をよく除去してあることを確認した上で、ゲージ検査を行って下さい。
特に砂埃が付着していると著しくゲージの摩耗を早めます。
- ・ゲージは通り側ゲージが通ることを確認してから、止り側ゲージが止ることを確認して下さい。
- ・管用テーパねじゲージで製品ねじを検査する場合、ゲージを最後まで急速にねじ込むと、衝撃的にねじ込まれ抜けなくなりますので、最後のねじ込みは慎重に行ってください。
- ・製品の口元の状態に、打コン、かえり等があるとゲージによる判定に狂いを生じさせます。
特に、ねじ製品の場合には不完全山の倒れによる判定誤差が生じやすくなります。
- ・通り側ゲージを通す時、あるいはゲージが抜けなくなった時にハンマー等で強く叩いたりして、衝撃を与えないで下さい。ゲージに傷、割れ、変形等を生じてゲージの機能を損ないます。
- ・ゲージを床に落としたり、ぶついたりした場合は、損傷の程度を確認しアルカンサス砥石でかえりを除去する等、適切な処理を行ってください。寸法変化の可能性があるものは精度検査を実施して下さい。
- ・ゲージが磁化した場合は、鉄粉等の付着によりゲージの摩耗を早めますので脱磁して下さい。

- ・ Please apply lubricating oil sufficiently when using the gauges. Please perform inspection after having confirmed that there is no dust, cutting powder sticking to the workpieces. Such the dust may accelerate the wear of gauges remarkably.
- ・ Please confirm that NOT GO side of the gauges stop after firstly confirming GO sides can go through.
- ・ When the threads are inspected using gauges for taper pipe thread, the gauges would be screwed rashly and can not be pulled out when the gauges are screwed rapidly till the last turn. Therefore, the gauges should be screwed carefully in the last turn.
- ・ The judgement of the gauges may be confused by the existence of any dent, burr on the edge of the workpieces. Especially for the thread products, a judgement error may easy to occur because of the incompleated threads.
- ・ Never give the gauges any shocks by hitting them using hammer when screwing or pulling out the gauges. Any shocks may yield wound, crack, and deformation and may exhaust gauges function.
- ・ When the gauges are fallen down into the floor or hited, please confirm the degree of the damage and take appropriate countermeasures, i.e., removing the burr using the Arkansas whetstone. Please carry out a precision inspection when there are any possibilities of changes in gauges dimensions.
- ・ When the gauges are magnetized, please demagnetize them because the adhesion of any iron powder may accelerate the wear of the gauges.



保管時の注意 Cautions during Storing

- ・製品とゲージ、あるいはプラグゲージとリングゲージ等をはめ合わせた状態で保管しないで下さい。密着したり、錆発生の原因になることがあります。
- ・ゲージを保管する際には、塵埃、切粉、指紋等をよく落とし錆対策を行ってください。またゲージは湿気がなく湿度変化の少ない場所に保管して下さい。
錆対策としては、ゲージを白灯油等の洗油で洗浄した後防錆油槽につけておく、もしくは防錆紙、防錆袋に入れておくまたはシールピールで包む等の方法があります。

- ・ Please never store the gauges in engaged condition, i.e., workpiece sticking to the gauge or plug gauge to ring gauge. Because it may cause corrosion.
- ・ Please take anti-corrosion measure when storing the gauges by cleaning the dust, cut-powder, and fingerprint. In addition, the gauges should be kept in a place with a little humidity changes. Anti-corrosion measure can be carried out by putting the gauges in a corrosion proof oil tank after having washed in washing oil, such as white kerosene, or by wrapping the gauges using the corrosion proof paper or Seal Peel.



寸法管理上の注意 Cautions for Dimension Control

- ・ゲージは摩耗に注意して下さい。使用頻度等を加味し、定期的な検査を実施して下さい。
特にゲージは先端部が摩耗しやすくなっていますので必ず先端を測定して下さい。
- ・ゲージ寸法は、20℃で定められていますので、環境温度が20℃でない場合は20℃に換算した後、寸法判定をして下さい。また比較測定の場合には、ブロックゲージとの温度差に注意して下さい。
- ・ゲージの測定時には、錆や温度上昇による寸法変化を防ぐために手袋やピンセット等を用い、素手で触れることは極力避けて下さい。

- ・ Please be aware of the wear of gauges. The gauges should be inspected periodically due to the accumulation of frequency use. The edge of the gauges should be measured by all means since the gauges wear easily in the edge part.
- ・ The dimensions of the gauges are basically measured under environment having temperature of 20°C. Please convert to the conditions of 20°C when the gauges are measured in the environment having different temperature. Be careful with the temperature difference with the block gauges in case of comparison measurement.
- ・ Do not touch the gauges barehanded to prevent any changes on dimension caused by temperature rise and corrosion. Use gloves or tweezers when measuring the gauges.

オヂヤセイキ会社概要

Introduction to OJIYA SEIKI



各種ゲージを中心とした測定器メーカーとして昭和41年(1966)年に創業し精密加工技術の研鑽と製造、検査設備の充実を図ってまいりました。

1991年11月にねじゲージの「JIS表示認定工場」となり、新たに2008年12月に新JISの認証を取得いたしました。

1999年11月にねじゲージをはじめとする各種ゲージの品質マネジメントシステム「ISO9001」を取得し、さらに2004年には環境マネジメントシステム「ISO14001」を取得いたしました。

また、販売面におきましてはお客様へのサービス体制の充実を図るため1997年に東京営業所を開設いたしました。

今後ともさらに研鑽を重ね、品質とサービスの維持向上に努め、お客様各位のご要望にお応えする所存でございますので、なお一層のご愛顧とお引き立てをお願い申し上げます。

OJIYA SEIKI CO., LTD, since established in 1966, has striven as a manufacture specialized in the production of various types of gauges, and subsequently expanded on the research and development of precision machining technologies, improved production facilities and inspection instruments.

OJIYA SEIKI CO., LTD has been approved as authorized factory for screw thread gauges by Japan Industrial Standard (JIS) in November 1991 and by New JIS standard in December 2008.

In November, 1999, OJIYAS SEIKI CO., LTD has been approved as authorized factory of ISO9001 (International Quality Management Systems). Furthermore, in 2004, our factory has been certified according to ISO14001 (International Environment Management Systems).

In order to improve our service system to our customer, we have established Tokyo sales office in 1997.

OJIYA SEIKI will continue to strive toward further improvement in the field of precision measurements on the basis of long experienced technology in order to satisfy our customer requirements.



OJIYAS

Brand of High Accuracy

当社周辺の景観
Surrounding scenery of OJIYAS



OJIYA SEIKI CO., LTD

名称 Company name	オヂヤセイキ株式会社 OJIYA SEIKI CO.,LTD.
所在地 Address	新潟県小千谷市平沢2丁目11番19号 2-11-19 HIRASAWA OJIYA-CITY, NIIGATA-PREF.,947-0042 JAPAN
創立 Established	1966年12月 December 1966
資本金 Capital	3,000万円 ¥30 million
従業員 Employees	105名 105
敷地 Site	18,576㎡ 18,576㎡
建物 Building	2,280㎡ 2,280㎡



JIS 認証
JQ 0308165
認証区分 Certificate Classification
JIS B 0251 メートルねじ用限界ゲージ
JIS B 0253 管用テーパねじゲージ
JIS B 0254 管用平行ねじゲージ
JIS B 0255 ユニファイねじ用限界ゲージ



ISO 9001 認証
JQA-QM 3908
登録活動範囲 Scope of Registration
各種ゲージ、空気マイクロメータの
設計・開発・製造および校正
Design/Development/Production and
Calibration of Precision Gauges, Air Gauges.
本社・東京営業所 Head office/Tokyo office



ISO 14001 認証
JQA-EM 3887
登録活動範囲 Scope of Registration
各種ゲージ、空気マイクロメータの
設計・開発・製造および校正
Design/Development/Production and
Calibration of Precision Gauges, Air Gauges.
本社・東京営業所 Head office/Tokyo office

OJIYAS

オチヤセイキ株式会社

OJIYA SEIKI CO., LTD.

本社・工場／ 〒947-0042 新潟県小千谷市平沢2丁目11番19号
Head office/Factory 2-11-19 HIRASAWA OJIYA-CITY, NIIGATA-PREF., 947-0042 JAPAN
TEL.0258-82-3331 FAX.0258-81-1288

営業部／ TEL.0258-81-1277 FAX.0258-83-4002
Sales division E-mail: eigyou@ojiyas.co.jp

東京営業所／ 〒101-0034 東京都千代田区神田東紺屋町28番地 那智ビル7F
Tokyo office 28 KANDA HIGASHI KONYA-CHO, CHIYODA-KU, TOKYO, 101-0034 JAPAN
TEL.03-5207-7211 FAX.03-3252-1160
E-mail: tokyo@ojiyas.co.jp

<http://www.ojiyas.co.jp>

本カタログに掲載された製品は、改良のため予告なく仕様変更を行うことがあります。
The products and specifications on this catalogue are subject to change without prior notice for improvement.

160210000 Printed in Japan