

ZEISS SPECTRUM®

Specifications

Version: November 2018



System description

Type according to ISO 10360-1:2000	Moving bridge CMM			
Operating mode	motorized / CNC			
Sensor mounts	Fixed installation / ZEISS RDS			
Software	ZEISS CALYPSO			
			5/5/6	7/7/6 and 7/10/6
Travel speed	Motorized	Axes	0 to 70 mm/s	0 to 70 mm/s
	CNC	Vector	max. 346 mm/s	max. 346 mm/s
Acceleration		Vector	max. 866 mm/s ²	max. 866 mm/s ²

Sensors and accuracy

The CMM specifications are only valid when using original accessories by ZEISS. The specified parameters are observed in the application of the internal test instructions for acceptance testing and in the use of the released standards in accordance with the ISO 10360 series.

ZEISS RDS-C5



Dynamic ZEISS RDS-C5 articulating unit for contact sensors. ZEISS RDS-C5 lateral swivel axis provides more advantages over articulating joints with front-to-back and lateral tilt axis; front-to-back and lateral tilt range of $\pm 180^\circ$, large measuring range, rotation increments of 5° , CAA correction for automatic calibration of all 5,184 angular positions for measuring contact sensors.

ZEISS VAST XXT and ZEISS XDT



Measuring contact sensor direct or on the ZEISS RDS-C5 articulating probe holder.

Stylus length with TL3 module = 30-150 mm; maximum sensor extension = 100 mm; maximum stylus weight = 15 g; minimum stylus tip diameter = 0.3 mm.

				5/5/6	7/7/6 and 7/10/6
Length measurement error ^{1) 2)} MPE complies with ISO 10360-2:2009	E0 ³⁾	in μm	ZEISS XDT and ZEISS VAST XXT	$1.9 + L/250$	$1.9 + L/250$
Single stylus form error MPE complies with ISO 10360-5:2010	PFTU ³⁾	in μm	ZEISS XDT and ZEISS VAST XXT	1.9	2.1
Scanning error MPE complies with ISO 10360-4:2000	THP	in μm		3.2	3.5
Required measuring time MPT	τ	in s		50	50
Form measurement error MPE for roundness complies with ISO 12181 (VDI/VDE 2617 sheet 2.2)	RONt (MZCI) ⁴⁾	in μm		1.8	1.9

Technical features

Length measuring system	Reflected light length measuring system, photoelectric 0.2 μm resolution		
Controller	Type	ZEISS C99L	
	Cooling system:	Fan	
Accessories (optional)	Standard control panel: 2 joysticks with progressive characteristics for manual control.		

Environmental requirements ⁵⁾

Relative humidity	40 - 60% (without condensation)		
Measuring reference temperature from	18°C to 22°C ⁶⁾		
	Per day	1.5 K/d	
	Per hour	1.0 K/h	
	Spatial	1.0 K/m	

Environmental for operational readiness

Relative humidity	40 - 60% (without condensation)		
Ambient temperature	+17°C to +35°C		

- 1) Acceptance test for ZEISS VAST XXT or ZEISS XDT with stylus length of 50 mm and sphere diameter of 3 mm.
- 2) Measuring length L in mm.
- 3) In compliance with the specified ambient conditions.
- 4) Roundness in scanning mode for $V_{\text{scan}} = 5 \text{ mm/s}$, filter 50 UPR.
- 5) To ensure specified accuracies.
- 6) At a measuring lab temperature that has remained constant for 48 hours.

ZEISS SPECTRUM Sizes	Dimensions in mm												Weight in kg		
	Measuring range			Overall CMM dimensions			Working range (Max. workpiece size)				Table height	Assem- bly space	Trans- port height ²⁾	CMM	Max. workpiece
	X axis	Y axis	Z axis	Width	Length	Height	Width	Length	Height	Height	Height	Height	Height		
G104	G105	G106	B6	B5	B7	B17	B16	B18	h	B23	c1	T			
5/5/6	500	500	600	1219	1281	2640	715	830	620 ¹⁾	845	650	≥200	2000	910	400
7/7/6	700	700	600	1419	1481	2640	915	1030	620 ¹⁾	845	650	≥200	2000	1180	560
7/10/6	700	1000	600	1419	1781	2640	915	1335	620 ¹⁾	845	650	≥200	2000	1410	730

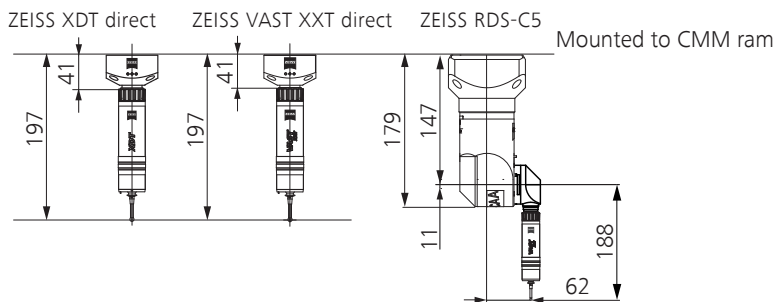
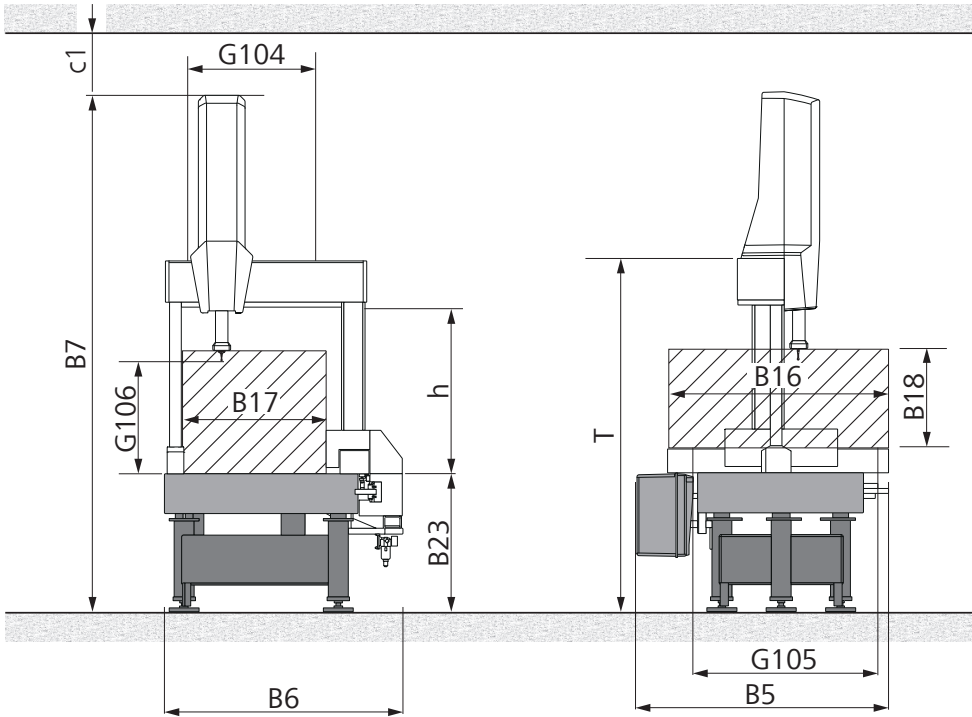

Note: The given dimensions and weights are approximate values. Subject to change. Actual appearance of specific sizes may vary from illustration. Measuring range in Z (G106) and working area height (B18) may vary depending upon probe configuration. Dimensioning based on DIN 4000-167:2009.

- 1) Valid for ZEISS XDT direct or ZEISS VAST XXT only (to bottom edge of the ZEISS XDT sensor). Working range height (B18) is less for other sensor configurations.
- 2) Transport height of the secured machine group without pallet or Z tower. When transporting without foundation, deduct 600 mm from the transport height value.

Connection data

Electrical	1/N/PE 100/110/115/120/125/230/240 VAC ~ ($\pm 10\%$); 50-60 Hz ($\pm 3.5\%$) Power consumption: max. 600 VA
Compressed air supply	Supply pressure min. 6 bar, max. 8 bar, pre-cleaned. Max. consumption: 120Nl/min. Air quality complies with ISO 8573 Part 1: Class 4, i.e. Paragraph 6.1: max. particle size 15 μm , max. dirt particle concentration 8 mg/m ³ Paragraph 6.2: max. compressed air dew point +3°C Paragraph 6.3: max. oil concentration of 5 mg/m ³ If the air supply does not comply with the above requirements, an additional air filter unit and, if necessary, a membrane dryer must be inserted in the compressed air line.

Approvals

Regulations	ZEISS SPECTRUM complies with EC machine directive 2006/42/EC and EMC directive 2014/30/EU.
Disposal	ZEISS products and packaging returned to us are disposed of in accordance with applicable legal provisions.

Certifications / accreditation

Quality management system	ISO 9001:2008; VDA 6, Parts 4, 2. Issue 2005
Environmental management system	ISO 14001:2004
Occupational health & safety management systems	BS OHSAS 18001:2007
Accredited	ISO / IEC 17025:2005

Carl Zeiss

Industrielle Messtechnik GmbH

73446 Oberkochen, Germany

Sales: +49 (0) 7364/ 20-6336

Service: +49 (0) 7364/ 20-6337

Fax: +49 (0) 7364/ 20-3870

Email: info.metrology.de@zeiss.com

Internet: www.zeiss.com/imt

Carl Zeiss

Industrial Metrology

6250 Sycamore Lane North

Maple Grove, MN 55369/USA

Phone: +1 (763) 744-2400

Fax: +1 (763) 533-0219

Email: info.metrology.us@zeiss.com

Internet: www.zeiss.com/metrology